

BNM No.: / (S) 18.08.04 / 2016-17

Dated: 05/10/2016

To,

(LIMITED TENDER)

TENDER NO. 03 / SAL / CSR / 2016 –2017

Dear Sir,

SUB: NIQ FOR CONSTRUCTION OF CLASS ROOM AT PINDRAKULI PRIMARY SCHOOL OF SALBONI BLOCK, PASCHIM MIDNAPORE.

Sealed quotations in two parts Techno-Commercial bid (Part-I) and Price bid (Part-II) are invited for “Construction of Class Room at Pindrakuli Primary School of Salboni Block, Paschim Midnapore” as per the terms & conditions mentioned in this Limited Tender. **You are requested to download the complete Tender Document from the website: www.brbnmpl.co.in.**

1. PRICE:

You are required to submit your competitive price as per Standard Bidding Document (SBD) in Price Bid Schedule, [Section XI](#) of this tender.

2. RECEIPT OF TENDER:

You are required to send your firm and binding quotation in two parts, Part-I consisting of ‘Techno-Commercial Bid’ & Part-II consisting of ‘Price Bid’ as per Standard Bidding Documents (SBD) of all the Sections of this tender. The quotation for ‘Techno-Commercial Bid’ should be submitted with all the Sections of Tender documents other than Section XI along with requisite EMD in a separate sealed envelope and to be superscribed as “**Techno Commercial Bid for Construction of Class Room at Pindrakuli Primary School of Salboni Block, Paschim Midnapore**”. The quotation for ‘Price Bid’ shall be submitted as per the format in Price Bid Schedule - [Section XI](#) of this tender in a separate sealed envelope and superscribed as “**Price Bid for Construction of Class Room at Pindrakuli Primary School of Salboni Block, Paschim Midnapore**”. Both the envelopes of ‘Techno-Commercial Bid’ & ‘Price Bid’ should be put together in a single sealed envelope and sent to the under mentioned address with a marking on the top of the cover as “**Quotation (Part I & II) for Construction of Class Room at Pindrakuli Primary School of Salboni Block, Paschim Midnapore**”.

Address: The General Manager
Bharatiya Reserve Bank Note Mudran Pvt Ltd.; Salboni
P.O. - Reserve Bank Note Mudran
Distt. West Midnapore, West Bengal -721132
Attn: Asst. General Manager (CSR)

You may visit the site and discuss on location & technicality with concerned officer during working hour (08:30 hrs. to 17:15 hrs.) on any working day before submitting your bid. Further, any query / clarification can be had from the following phone numbers: -

Tender- Construction of Class Room at Pindrakuli Primary School of Salboni Block, Paschim Midnapore.

AGM (CSR) - (03227) 280695

Asst. Manager (CSR) - (03227) 280212 /213 Extn. No.: 4311/ 4313

All the pages of tender documents shall be duly signed & submitted by the tenderer along with Techno-Commercial bid as a token of having read and accepted all the terms & conditions.

3. IMPORTANT DATES:

Duly completed quotation should reach us on or before **28/10/2016 up to 11:30 hrs.** The quotations for Techno-Commercial bid will be opened on the same day (**i.e. 28/10/2016**) at **11:30 hrs.** The Price bid quotations for those, who qualify in the Techno-Commercial bid, will be opened at later stage and same will be informed. We will appreciate your presence during opening of the quotations. BRBNMPL is not responsible for any postal delay and quotation shall not be accepted after due date and time.

4. EARNEST MONEY DEPOSIT / SECURITY DEPOSIT:

E.M.D.: An EMD of **Rs 21,500/- (Rupees Twenty one thousand Five hundred only)** is payable in the form of Demand Draft / Banker's Cheque / Fixed Deposit drawn in favour of Bharatiya Reserve Bank Note Mudran Pvt. Ltd., payable at par at the State Bank of India, Salboni (Code No.3558) drawn from any Branch of SBI in India. If drawn from any Associate Bank of SBI or any other Scheduled Commercial Bank in India, it should be payable at par at Midnapore. **Tender without EMD shall be liable for rejection.** EMD will be returned as applicable to the unsuccessful bidders without any interest, after the finalisation of the contract. For successful bidder, it will be converted as part of Security deposit, which is 10% of order value and returned after completion of defect liability period of one year from virtual date of completion. **The successful bidder has to submit balance amount of Security Deposit within 21 days after issue of Work Order.** It may be noted that no interest will be paid while returning the EMD / Security Deposit. EMD amount will be forfeited, if any of the bidders fails or refuses to take up the job after opening the quotation and becoming the successful bidder, due to any reason whatsoever without any notice.

BRBNMPL reserves the right to accept/reject/cancel any or all tenders without assigning any reason thereof. BRBNMPL is not bound to accept the lowest or any tender or assign any reason for non- acceptance. Mere qualifying as Lowest Bidder in terms of price may not qualify for issue of work order. BRBNMPL also reserves the right to accept the tender in whole or part. Incomplete tender or tender not submitted in accordance with the directions issued shall be liable for rejection.

For and on behalf of
Bharatiya Reserve Bank Note Mudran Pvt. Ltd.,

-Sd-

(Rajaram M. Shetty)
Asst. General Manager

Tender- Construction of Class Rooms at Pindrakuli Primary School of Salboni Block, Paschim Midnapore.

BHARATIYA RESERVE BANK NOTE MUDRAN PRIVATE LIMITED
PO: RBNM, SALBONI, DISTRICT - WEST MIDNAPORE, WEST BENGAL – 721132
Phone No. 0091-03227-280212,280213, Fax No. 0091-03227-280744,280222
E-mail: salbonipress@brbnmpl.co.in, website: www.brbnmpl.co.in

Not Transferable

Security Classification: Non –Security Item

TENDER DOCUMENT FOR CONSTRUCTION OF CLASS ROOM AT PINDRAKULI PRIMARY SCHOOL OF SALBONI BLOCK, PASCHIM-MIDNAPORE

Tender No. 03/SAL/CSR/2016-17

Dated: 01/10/2016

This tender document contains **74 pages**

The tender document is issued to:

M/s. _____
Address _____

Details of Contact person in BRBNMPL regarding this tender:

Name- Shri. Rajaram M. Shetty Designation: Assistant General Manager

Address: Bharatiya Reserve Bank Note Mudran Private Limited

PO: RBNM, Salboni

District - West Midnapore, West Bengal - 721132

Phone: 03227-280695

Fax :03227-280744, 280222

Email: rajaram@brbnmpl.co.in

Name- Shri. P. K. Samantaray, Designation: Asstt. Manager (CSR)

Address: Bharatiya Reserve Bank Note Mudran Private Limited

PO: RBNM, Salboni

District - West Midnapore, West Bengal - 721132

Phone: 03227-280212 / 213 (Extn.: 4311 & 4313)

Fax :03227-280744,

E-mail: pkrray@brbnmpl.co.in

Tender- Construction of Class Room at Pindrakuli Primary School of Salboni Block, Paschim Midnapore.

Contents	Page No.
<u>Section I: Notice Inviting Tender (NIT).....</u>	<u>05</u>
<u>Section II: General Instructions to Tenderers (GIT).....</u>	<u>07</u>
<u>Part I: General Instructions Applicable to all Types of Tenders.....</u>	<u>07</u>
<u>Part II: Additional General Instructions Applicable to Specific Types of Tenders: ...</u>	<u>25</u>
<u>Section III: Special Instructions to Tenderers (SIT).....</u>	<u>28</u>
<u>Section IV: General Conditions of Contract (GCC).....</u>	<u>34</u>
<u>Section V: Special Conditions of Contract (SCC).....</u>	<u>54</u>
<u>Section VI: Questionnaire.....</u>	<u>55</u>
<u>Section VII: Technical Specifications.....</u>	<u>57</u>
<u>Section VIII: Quality Control Requirements.....</u>	<u>58</u>
<u>Section IX: Qualification / Eligibility Criteria.....</u>	<u>58</u>
<u>Section X: Tender Form.....</u>	<u>59</u>
<u>Section XI: Price Schedule.....</u>	<u>60</u>
<u>Section XII: List Of Requirements.....</u>	<u>71</u>
<u>Section XIII: Bank Guarantee Form for Performance Security.....</u>	<u>72</u>
<u>Section XIV: Letter of Authority for attending a Bid Opening.....</u>	<u>73</u>
<u>Section XV: Proforma of Bills for Payment.....</u>	<u>74</u>

Tender- Construction of Class Room at Pindrakuli Primary School of Salboni Block, Paschim Midnapore.

Section I: Notice Inviting Tender (NIT)

BHARATIYA RESERVE BANK NOTE MUDRAN PRIVATE LIMITED

PO: RBNM, SALBONI, WEST MIDNAPORE DISTRICT WEST BENGAL – 721132

Phone No. 0091-03227-280212, 280213, Fax No. 0091-03227-280744, 280222

E-mail: salbonipress@brbnmpl.co.in, website: www.brbnmpl.co.in

Tender No.03/SAL/CSR/2016-2017.

Date: 01/10/2016

1. Sealed tenders are invited for CONSTRUCTION OF CLASS ROOM AT PINDRAKULI PRIMARY SCHOOL OF SALBONI BLOCK, PASCHIM-MIDNAPORE.

Schedule No.	Brief Description of Goods / Services	Quantity (with unit)	Earnest Money (in Rs.)	Remarks
1.	Construction of Class Room at Pindrakuli Primary School of Salboni Block, Paschim Midnapore.	One Numbers	Rs 21,500/- (Rupees Twenty one thousand Five hundred only)	Estimated Cost: Rs.: 10,72,000/- (Rs.: Ten lakh Seventy two thousand only) <u>Including Service Tax</u>

Type of Tender (Two Bid / PQB / EOI / RC / Development / Indigenization / Disposal of Scrap / Security item etc.	Limited Tender, Two bid (Techno Commercial bid and Price Bid)
Date of Sale of Tender documents	Not Applicable for Limited Tender among enlisted contractors of BRBNMPL, Salboni.
Price of the Tender Document	NIL for enlisted Contractors and Rs.500/- for Others.
Closing date and time for receipt of tenders	28/10/2016 upto 11:30 Hrs.
Place of receipt of tenders	Inward Dispatch Section, 1 st Floor Administrative Building, BRBNMPL, Salboni
Time and date of opening of tenders	11:30 Hrs on 28/10/2016
Place of opening of tenders	Administrative Building, BRBNMPL, Salboni
Nominated Person / Designation to Receive Bulky Tender (Clause 21.21.1 of GIT)	Section- in-charge - Office Management Section, Admin Division, 1 st Floor, BRBNMPL, Salboni

Tender- Construction of Class Room at Pindrakuli Primary School of Salboni Block, Paschim Midnapore.

2. Interested Tenderer may obtain further information about this requirement from the above office. They may also visit our website mentioned above for further details.
3. Tenderers may download the complete tender documents from the web site :www.brbnmpl.co.in.
4. Tenderers shall ensure that their tenders, duly sealed and signed, complete in all respects as per instructions contained in the Tender Documents, are dropped in the tender box kept in the entrance of our Administrative building after taking the endorsement at our inward section in 1st floor of Administrative Building on or before the closing date and time indicated in the Para 1 above, failing which the tenders will be treated as late and rejected.
5. In the event of any of the above mentioned dates being declared as a holiday / closed day for BRBNMPL, the tenders will be received / opened on the next working day at the appointed time.
6. The tender documents are not transferable.

Yours faithfully,
For and on behalf of
Bharatiya Reserve Bank Note Mudran Private Limited, Salboni

-Sd-

(Rajaram M. Shetty)
Asst.General Manager

Tender- Construction of Class Room at Pindrakuli Primary School of Salboni Block, Paschim Midnapore.

Section II: General Instructions to Tenderer (GIT)

Part I: General Instructions Applicable to all Types of Tenders

A PREAMBLE

M/s Bharatiya Reserve Bank Note Mudran Pvt. Limited (BRBNMPL) is a wholly owned subsidiary of Reserve Bank of India engaged in the sovereign function of currency note printing which is situated at Salboni, Dist-West Midnapore in the state of West Bengal. It desires to enter into contract for Construction of Class Room at Pindrakuli Primary School of Salboni Block, Paschim Midnapore, with a reliable, efficient, experienced contractor in order to construct Class Room at nearby village schools under CSR programme. This work is required to be completed in all respect according to the intent and meaning of specification and description referred to in the Schedule of rates. Actual quantity may vary from B.O.Q. and bill shall be paid as per the actual work done. After quoting rates any claim due to ignorance of site condition or any other account shall not be considered at all.

1. Introduction

- 1.1** Definitions and abbreviations, which have been used in these documents, shall have the meanings as indicated in GCC.
- 1.2** For sake of convenience, whole of this Bidding Document (including all sections) is written in reference to this Tender. Therefore the construction of all clauses are to be interpreted in the context of particular type of tender beyond the letter of the clause, read with the additional clauses for the specific type of tenders in Part II GIT/ GCC.
- 1.3** These tender documents have been issued for the requirements mentioned in [Section - XII - "List of Requirements"](#), which also indicates, inter-alia, the required **Service schedule**.
- 1.4** This section (Section II - "General Instruction to Tenderers" - GIT) provides the relevant information as well as instructions to assist the prospective tenderers in preparation and submission of tenders. It also includes the mode and procedure to be adopted for receipt and opening as well as scrutiny and evaluation of tenders and subsequent placement of contract. With this limited objective, GIT is not intended to be complete by itself and the rest of this document - SIT, GCC and SCC in particular may also be thoroughly studied before filling up the Tender Document. There would be certain topics covered in GIT/SIT as well as in GCC/ SCC from different perspectives. In case of any conflict between these, provisions of GCC/ SCC would prevail.
- 1.5** The tenderers shall also read the Special Instructions to Tenderers (SIT) related to this service, as contained in Section III of these documents and follow the same accordingly. Whenever there is a conflict between the GIT and the SIT, the provisions contained in the SIT shall prevail over those in the GIT.

2. Language of Tender

The tender submitted by the tenderer and all subsequent correspondence and documents relating to the tender exchanged between the tenderer and BRBNMPL, shall be written in English language, unless otherwise specified in the Tender. However, the language of any printed literature furnished by the tenderer in connection with its tender may be written in any other language provided the same is accompanied by English translation. For purposes of interpretation of the tender, the English translation shall prevail.

Tender- Construction of Class Room at Pindrakuli Primary School of Salboni Block, Paschim Midnapore.

3. Eligible Tenderers

This invitation for tenders is limited to all enlisted contractors who fulfill the eligibility criteria specified in these documents. Please refer to Section IX: Qualification/ Eligibility Criteria

4. Eligible Services

All related services to be provided under the contract shall have their origin in India or other countries, subject to any restriction imposed in this regard in Section III (SIT). The term "origin" used in this clause means the place where the goods are mined, grown, produced or manufactured or from where the related services are arranged and provide.

5. Tendering Expense

The tenderer shall bear all costs and expenditure incurred and/ or to be incurred by it in connection with its tender including preparation, mailing and submission of its tender and for subsequent processing the same. BRBNMPL will, in no case be responsible or liable for any such cost, expenditure etc regardless of the conduct or outcome of the tendering process.

B TENDER DOCUMENTS

6. Content of Tender Documents

6.1 The tender documents includes:

1. Section I - Notice Inviting Tender (NIT)
2. Section II - General Instructions to Tenderers (GIT)
3. Section III - Special Instructions to Tenderers (SIT)
4. Section IV -General Conditions of Contract (GCC)
5. Section V - Special Conditions of Contract (SCC)
6. Section VI - Questionnaire
7. Section VII - Technical Specifications
8. Section VIII - Quality Control Requirements
9. Section IX — Qualification/ Eligibility Criteria
10. Section X - Tender Form
11. Section XI - Price Schedule
12. Section XII –List of Requirements
13. Section XIII - Bank Guarantee Form for Performance Security
14. Section XIV - Letter of Authority for attending a Bid Opening
15. Section XV - Proforma of Bills for Payment

6.2 The relevant details of the required services, the terms, conditions and procedure for tendering, tender evaluation, placement of contract, the applicable contract terms and, also, the standard formats to be used for this purpose are incorporated in the abovementioned documents. The interested tenderers before formulating the tender and submitting the same to BRBNMPL, should read and examine all the terms, conditions, instructions etc. contained in the tender documents. Failure to provide and/ or comply with the required information, instructions etc. incorporated in these tender documents may result in rejection of its tender.

Tender- Construction of Class Room at Pindrakuli Primary School of Salboni Block, Paschim Midnapore.

7. Amendments to Tender Documents

- 7.1 At any time prior to the deadline for submission of tenders, BRBNMPL may, for any reason deemed fit by it, modify the tender documents by issuing suitable amendments) to it.
- 7.2 Such an amendment will be notified in writing by registered/ speed post or by fax / telex / e-mail, followed by copy of the same by suitable recorded post to all prospective tenderers, which have received the tender documents and will be binding on them.
- 7.3 In order to provide reasonable time to the prospective tenderers to take necessary action in preparing their tenders as per the amendment, BRBNMPL may, at its discretion extend the deadline for the submission of tenders and other allied time frames, which are linked with that deadline.

8. Pre-Bid conference

Not applicable for this tender.

9. Clarification of Tender Documents

A Tenderer requiring any clarification or elucidation on any issue of the tender documents may take up the same with BRBNMPL in writing or by fax / e-mail / telex. BRBNMPL will respond in writing to such request provided the same is received by BRBNMPL not later than twenty one days (unless otherwise specified in the SIT) prior to the prescribed date of submission of tender. Copies of the query and clarification shall be sent to all prospective bidders who have received the bidding documents.

C PREPARATION OF TENDERS

10. Documents Comprising the Tender

- 10.1 The tender to be submitted by Tenderer shall contain the following documents, duly filled in, as required:
- a) Tender Form and Price Schedule along with list of deviations (ref Clause 19.19.4) from the clauses of this BD, if any.
 - b) Documentary evidence, as necessary in terms of GIT clauses 3 and 16 establishing that the tenderer is eligible to submit the tender and, also, qualified to perform the contract if its tender is accepted.
 - c) Documents and relevant details to establish in accordance with GIT clause 17 that the goods and the allied services to be supplied by the tenderer conform to the requirement of the tender documents along with list of deviations if any (ref clause 17.17.3 of GIT).
 - d) Earnest money furnished in accordance with GIT clause 18.18.1 alternatively, documentary evidence as per GIT clause 18.18.2 for claiming exemption from payment of earnest money.

Tender- Construction of Class Room at Pindrakuli Primary School of Salboni Block, Paschim Midnapore.

- e) Questionnaire as per Section VI.
- f) Contractor's Authorization Form (Ref Section XIV, if applicable)

NB: The tenderers may also enclose in their tenders, technical literature and other documents as and if considered necessary by them.

10.2 A tender, that does not fulfill any of the above requirements and / or gives evasive information / reply against any such requirement, shall be liable to be ignored and rejected.

10.3 Tender sent by fax/email/ telex/ cable shall be ignored.

11. Tender currencies

11.1 Unless otherwise specified, the tenderer shall quote only in Indian rupees.

11.2 Where the tender condition specifies acceptance of quotations in different currencies, then, for domestic goods, prices shall be quoted in Indian rupees only and for imported goods, prices shall be quoted either in Indian rupees or in the currency stipulated in the SIT, mentioning, inter-alia, the exchange rate adopted for converting foreign currency into Indian Rupees. As regards price(s) for allied services, if any required with the goods, the same shall be quoted in Indian Rupees if such services are to be performed / undertaken in India. Commission for Indian Agent, if any and if payable shall be indicated in the space provided for in the price schedule and quoted in Indian Rupees only,

11.3 Tenders, where prices are quoted in any other way shall be treated as unresponsive and rejected.

12. Tender Prices

12.1 The Tenderer shall indicate on the Price Schedule provided under Section XI all the specified components of prices shown therein including the unit prices and total tender prices of the services it proposes to supply against the requirement. All the columns shown in the price schedule should be filled up as required. If any column does not apply to a tenderer, the same should be clarified accordingly by the tenderer.

12.2 If there is more than one schedule in the List of Requirements, the tenderer has the option to submit its quotation for any one or more schedules and, also, to offer special discount for combined schedules. However, while quoting for a schedule, the tenderer shall quote for the complete requirement of services as specified in that particular schedule.

12.3 The quoted prices for services offered for Operation and Maintenance from within India and that for goods offered from abroad are to be indicated separately in the applicable Price Schedules attached under Section XI.

Tender- Construction of Class Room at Pindrakuli Primary School of Salboni Block, Paschim Midnapore.

12.4 While filling up the columns of the price schedule, the following aspects should be noted for compliance:

12.5 For goods offered from within India, the prices in the corresponding price schedule shall be entered separately in the following manner:

- a) The price of the goods, quoted ex-factory, ex-showroom, ex-warehouse or off-the-shelf, as applicable, including all taxes and duties like sales tax, VAT, custom duty, excise duty etc. already paid or payable on the components and raw material used in the manufacture or assembly of the goods quoted ex-factory etc or on the previously imported goods of foreign origin quoted ex-showroom etc.
- b) Any sales or other taxes and any duties including excise duty, which will be payable on the goods in India if the contract is awarded.
- c) Charges towards inland transportation, insurance and other local costs incidental to delivery of the goods to their final destination as specified in the List of Requirements and
- d) The price of incidental services, as and if mentioned in List of Requirements.

12.6 For goods offered from abroad, the prices in the corresponding price schedule shall be entered separately in the following manner: **[Not Applicable]**

- a) The price of goods quoted FAS / FOB port of shipment, CIF port of entry in India or CIF specified place of destination in India as indicated in the List of Requirements,
- b) Wherever applicable, the amount of custom duty and import duty on the goods to be imported.
- c) The charges for inland transportation, insurance and other local costs incidental to delivery of the goods from the port of entry in India to their final destination, as specified in the List of Requirements. And
- d) The charges for incidental services, as and if mentioned in the List of Requirements.

12.7 Additional information and instruction on Duties and Taxes:

If the Tenderer desires to ask for excise duty, sales tax, custom duty etc. to be paid extra, the same must be specifically stated. In the absence of any such stipulation the price will be taken inclusive of such duties and taxes and no claim for the same will be entertained later.

12.8 Excise Duty:

- a) If reimbursement of excise duty is intended as extra over the quoted prices, the contractor must specifically say so also indicating the rate, quantum and nature of the duty applicable. In the absence of any such stipulation it will be presumed that the prices quoted are firm and final and no claim on account of excise duty will be entertained after the opening of tenders.

Tender- Construction of Class Room at Pindrakuli Primary School of Salboni Block, Paschim Midnapore.

- b) If a Tenderer chooses to quote a price inclusive of excise duty and also desires to be reimbursed for variation, if any, in the excise duty during the time of supply, the tenderer must clearly mention the same and also indicate the rate and quantum of excise duty included in its price. Failure to indicate all such details in clear terms may result in statutory variations being denied to the tenderer.
- c) Subject to sub clauses 12.8 {a} & (b) above, any change in excise duty upward/downward as a result of any statutory variation in excise duty taking place within original Delivery Period shall be allowed to the extent of actual quantum of excise duty paid by the supplier. In case of downward revision in excise duty, the actual quantum of reduction of excise duty shall be reimbursed to BRBNMPL by the supplier. All such adjustments shall include all reliefs, exemptions, rebates, concession etc. if any obtained by the supplier.

12.9 Sales Tax/ VAT/ CST/ GST:

If a tenderer asks for sales tax/ VAT/ CST/ GST to be paid extra, the rate and nature of such taxes applicable should be shown separately. Such taxes will be paid as per the rate at which it is liable to be assessed or has actually been assessed provided the transaction of sale is legally liable to such taxes and is payable as per the terms of the contract.

12.10 Wherever Value Added Tax is applicable, the following may be noted:

- i) The tenderer should quote the exact percentage of VAT that they will be charging extra.
- ii) While quoting the rates, tenderer should pass on (by way of reduction in prices) the set off/input tax credit that would become available to them by switching over to the system of VAT from the existing system of sales tax, duly stating the quantum of such credit per unit of the item quoted for.
- iii) The tenderer while quoting for tenders should give the following declaration:

"We agree to pass on such additional set off/input tax credit as may become available in future in respect of all the inputs used in the manufacture of the final product on the date of supply under the VAT scheme by way of reduction in price and advise the purchaser accordingly."

- iv) The supplier while claiming the payment shall furnish the following certificate to the paying authorities: We hereby declare that additional set offs / input tax credit to the tune of Rs..... has accrued and accordingly the same is being passed on to the purchaser and to that effect the payable amount may be adjusted .

Tender- Construction of Class Room at Pindrakuli Primary School of Salboni Block, Paschim Midnapore.

12.11 Octroi and Local Taxes:

Unless otherwise stated in the SIT, the goods supplied against contracts placed by BRBNMPL are not exempted from levy of Town Duty, Octroi Duty, Terminal Tax and other Levies of local bodies. In such cases, the contractor should make the payment to avoid delay in supplies and forward the receipt of the same to the purchasing department for reimbursement and, also, for further necessary action. In cases where exemption is available, suppliers should obtain the exemption certificate from the purchasing department to avoid payment of such levies and taxes.

12.12 Duties/ Taxes on Raw Materials

BRBNMPL is not liable for any claim from the contractor on account of fresh imposition and / or increase (including statutory increase) of excise duty, custom duty, sales tax etc. on raw materials and/or components used directly in the manufacture of the contracted goods taking place during the pendency of the contract, unless such liability is specifically agreed to in terms of the contract.

12.13 Imported Stores not liable to Above-mentioned Taxes and Duties: (Not Applicable)

Above mentioned Taxes and Duties are not leviable on imported Goods and hence would not be reimbursed.

12.14 Customs Duty: (Not Applicable)

In respect of imported stores offered from abroad, the tenderer shall specify the rate as well as the total amount of customs duty payable. The tenderer shall also indicate the corresponding Indian Customs Tariff Number applicable for the goods in question.

12.14.1. For transportation of imported goods offered from abroad, relevant instructions as incorporated under GCC Clause 11 shall be followed.

12.14.2. For insurance of goods to be supplied, relevant instructions as provided under GCC Clause 12 shall be followed.

12.14.3. Unless otherwise specifically indicated in this tender document, the terms FOB, FAS, CIF etc. for imported goods offered from abroad, shall be governed by the rules & regulations prescribed in the current edition of INCOTERMS, published by the International Chamber of Commerce, Paris

12.14.4. The need for indication of all such price components by the tenderers, as required in this clause (viz., GIT clause 12) is for the purpose of comparison of the tenders by BRBNMPL and will no way restrict BRBNMPL's right to award the contract on the selected tenderer on any of the terms offered.

13. Indian Agent (Not Applicable)

If a foreign tenderer has engaged an agent in India in connection with its tender, the foreign tenderer, in addition to indicating Indian agent's commission, if any, in a manner described under GIT sub clause 11.2 above, shall also furnish the following information:

Tender- Construction of Class Room at Pindrakuli Primary School of Salboni Block, Paschim Midnapore.

- a) The complete name and address of the Indian Agent and its permanent income tax account number as allotted by the Indian Income Tax authority.
- b) The details of the services to be rendered by the agent for the subject requirement

One manufacturer can authorize only one agent/ dealer. Also one agent cannot represent more than one supplier or quote on their behalf in a particular tender enquiry. Such quote is likely to be rejected. There can be only one bid from

- a) The principal manufacturer directly or one Indian agent on his behalf.
- b) The foreign principal or any of its branch/ division
- c) Indian/ Foreign Agent on behalf of only one Principal.

14. Firm Price / Variable Price

- 14.1 Unless otherwise specified in the SIT, prices quoted by the tenderer shall remain firm and fixed during the currency of the contract and not subject to variation on any account.
- 14.2 In case the tender documents require offers on variable price basis, the price quoted by the tenderers will be subject to adjustment during original Delivery Period to take care of the changes in the cost of labour and material components in accordance with the price variation formula to be specified in the SIT. If a tenderer submits firm price quotation against the requirement of variable price quotation, that tender will be prima-facie acceptable and considered further, taking price variation asked for by the tenderer as zero.
- 14.3 However, as regards taxes and duties, if any, chargeable on the goods and payable, the conditions stipulated in GIT clause 12 will apply for both firm price tender and variable price tender.
- 14.4 Subject to provisions of Clause 11 above, where prices are quoted in foreign currencies, involving imports - Foreign Exchange Rate Variation (ERV) would be borne by the Purchaser within the original Delivery Period. The offer of the Tenderer should indicate import content and the currency used for calculating import content. **(Not applicable)**
- 14.5 Base Exchange rate of each major currency used for calculating FE content of the contract should be indicated. The base date of ERV would be contract date and variation on the base date can be given up to the midpoint manufacture, unless firm has already indicated the time schedule within which material will be imported by the firm. **(Not applicable)**
- 14.6 In case delivery period is refixed / extended, ERV will not be admissible, if this is due to default of the supplier. **(Not applicable)**
- 14.7 Documents for claiming ERV:
 - i. A bill of ERV claim enclosing working sheet **(Not applicable)**
 - ii. Banker's Certificate/debit advice detailing F.E. paid and exchange rate
 - iii. Copies of import order placed on supplier
 - iv. Invoice of supplier for the relevant import order

Tender- Construction of Class Room at Pindrakuli Primary School of Salboni Block, Paschim Midnapore.

15. Alternative Tenders

Unless otherwise specified in the Schedule of Requirements, alternative tenders shall not be considered.

16. Documents Establishing Tenderer's Eligibility and Qualifications

- 16.1 Pursuant to GIT clause 10, the tenderer shall furnish, as part of its tender, relevant details and documents establishing its eligibility to quote and its qualifications to perform the contract if its tender is accepted.
- 16.2 The documentary evidence needed to establish the tenderer's qualifications should fulfill the following requirements:
- a) In case the tenderer offers to supply goods, which are manufactured by some other firm, the tenderer has been duly authorized by the goods manufacturer to quote for and supply the goods to BRBNMPL.
 - b) The tenderer has the required financial, technical and production capability necessary to perform the contract and, further, it meets the qualification criteria incorporated in the Section IX in these documents.
 - c) In case the tenderer is not doing business in India, it is/ will be duly represented by an agent stationed in India fully equipped and able to carry out the required contractual functions and duties of the contractor including after sale service, maintenance & repair etc. of the goods in a question, stocking of spare parts and fast moving components and other obligations, if any, specified in the conditions of contract and/ or technical specifications.
 - d) In case the tenderer is an Indian agent quoting on behalf of a foreign manufacturer, the Indian agent is already enlisted under the Compulsory Enlistment Scheme of Ministry of Finance, Govt. of India, operated through Directorate General of Supplies & Disposals (DGS&D), New Delhi. **(Not applicable)**

17. Documents establishing Good's Conformity to Tender document

- 17.1 The tenderer shall provide in its tender the required as well as the relevant documents like technical data, literature, drawings etc. to establish that the goods and services offered in the tender fully conform to the goods and services specified by BRBNMPL in the tender documents. For this purpose the tenderer shall also provide a clause-by-clause commentary on the technical specifications and other technical details incorporated by BRBNMPL in the tender documents to establish technical responsiveness of the goods and services offered in its tender.
- 17.2 In case there is any variation and/ or deviation between the goods & services prescribed by BRBNMPL and that offered by the tenderer, the tenderer shall list out the same in a chart form without ambiguity along with justification, and provide the same along with its tender.
- 17.3 If a tenderer furnishes wrong and/ or misleading data, statement(s) etc. about technical acceptability of the goods and services offered by it, its tender will be liable to be ignored and rejected in addition to other remedies available to BRBNMPL in this regard.

Tender- Construction of Class Room at Pindrakuli Primary School of Salboni Block, Paschim Midnapore.

18. Earnest Money Deposit (EMD)

- 18.1 Pursuant to GIT clause 10.1(d) the tenderer shall furnish along with its tender, earnest money for amount as shown in the List of Requirements. The earnest money is required to protect BRBNMPL against the risk of the Tenderers unwarranted conduct as amplified under sub-clause 23.23.2 below.
- 18.2 The tenderers who are currently registered and, also, will continue to remain registered during the tender validity period with DGS&D or with National Small Industries Corporation are exempted from payment of earnest money. In case the tenderer falls in these categories, it should furnish certified copy of its valid registration details (with DGS&D or NSIC as the case may be).
- 18.3 The earnest money shall be denominated in Indian Rupees.
- 18.4 The earnest money shall be furnished in one of the following forms:
- a) Account Payee Demand Draft or
 - b) Fixed Deposit Receipt or
 - c) Banker's cheque
- The demand draft, fixed deposit receipt or banker's cheque shall be drawn on any scheduled commercial bank in India, in favour of Account specified in the Clause 4 of the forwarding letter of NIT. The earnest money shall be valid for a period of forty-five days beyond the validity period of the tender.
- 18.5 Earnest money of unsuccessful tenderer's will be returned to them without any interest, after expiry of the tender validity period, but not later than thirty days after conclusion of the resultant contract. Successful Tenderer's earnest money will be returned without any interest, after receipt of performance security from that tenderer.
- 18.6 Earnest money of a tenderer will be forfeited, if the tenderer withdraws or amends its tender or impairs or derogates from the tender in any respect within the period of validity of its tender. The successful tenderer's earnest money will be forfeited if it fails to furnish the required performance security within the specified period.

19. Tender Validity

- 19.1 If not mentioned otherwise in the SIT, the tenders shall remain valid for acceptance for a period of 90 days (Ninety days) in case of single bid tender system and **120 days** in case of two-bid system after the date of tender opening prescribed in the tender document. Any tender valid for a shorter period shall be treated as unresponsive and rejected.

Tender- Construction of Class Room at Pindrakuli Primary School of Salboni Block, Paschim Midnapore.

- 19.2 In exceptional cases, the tenderers may be requested by BRBNMPL to extend the validity of their tenders upto a specified period. Such request(s) and responses thereto shall be conveyed by surface mail or by fax /email /telex /cable followed by surface mail. The tenderers, who agree to extend the tender validity, are to extend the same without any change or modification of their original tender and they are also to extend the validity period of the EMD accordingly.
- 19.3 In case the day upto which the tenders are to remain valid falls on/ subsequently declared a holiday or closed day for BRBNMPL, the tender validity shall automatically be extended upto the next working day.
- 19.4 Compliance with the Clauses of this Tender Document: Tenderer must comply with all the clauses of this Tender Document. In case there are any deviations, these should be listed in a chart form without any ambiguity along with justification.

20. Signing and Sealing of Tender

- 20.1 An authenticated copy of the document which authorizes the signatory to commit on behalf of the firm shall accompany the offer. The individual signing the tender or any other documents connected therewith should clearly indicate his full name and designation and also specify whether he is signing,
- (a) As Sole Proprietor of the concern or as attorney of the Sole Proprietor;
 - (b) As Partner (s) of the firm;
 - (c) As Director, Manager or Secretary in case the of Limited Company duly authorized by a resolution passed by the Board of Directors or in pursuance of the Authority conferred by Memorandum of Association.
- 20.2 The authorized signatory of the tenderer must sign the tender at appropriate places and initial the remaining pages of the tender.
- 20.3 The tenderers shall submit their tenders as per the instructions contained in G1T Clause
- 20.4 Unless otherwise mentioned in the SIT, a tenderer shall submit single copy of its tender.
- 20.5 The original and other copies of the tender shall either be typed or written in indelible ink and the same shall be signed by the tenderer or by a person(s) who has been duly authorized to bind the tenderer to the contract. The letter of authorization shall be by a written power of attorney, which shall also be furnished along with the tender.
- 20.6 All the copies of the tender shall be duly signed at the appropriate places as indicated in the tender documents and all other pages of the tender including printed literature, if any shall be initialed by the same person(s) signing the tender. The tender shall not contain any erasure or overwriting, except as necessary to correct any error made by the tenderer and, if there is any such correction; the same shall be initialed by the person(s) signing the tender.

Tender- Construction of Class Room at Pindrakuli Primary School of Salboni Block, Paschim Midnapore.

- 20.7 The tenderer is to seal the tender in separate envelopes and writing the address of BRBNMPL and the tender reference number on the envelopes. The sentence '**NOT TO BE OPENED**' before (The tenderer is to put the date & time of tender opening) are to be written on these envelopes. The inner envelopes are then to be put in a bigger outer envelope, which will also be duly sealed, marked etc. as above. If the outer envelope is not sealed and marked properly as above, BRBNMPL will not assume any responsibility for its misplacement, premature opening, late opening etc.
- 20.8 For purchasing capital equipment, high value plant, machinery etc. of complex and technical nature, tender document will seek quotation in two parts (Two Bid System)- first part containing the relevant technical details of the equipment / machinery etc., and in the second part, price quotation along with other allied issues. First part will be known as 'Technical Bid', and the second part 'Financial bid'. Tenderer shall seal separately 'Technical Bid' and 'Financial bid' and covers will be suitably super scribed. Both these sealed covers shall be put in a bigger cover and sealed and evaluation would be done as described in clause 24.4 below. Further details would be given in SIT, if considered necessary.
- 20.9 If permitted in the SIT, the tenderer may submit its tender through e-tendering procedure.

D SUBMISSION OF TENDERS

21. Submission of Tenders

- 21.1 Unless otherwise specified, the tenderers are to deposit the tenders in the tender box kept for this purpose at a place as indicated in Para 1 of NIT. In case of bulky tender, which cannot be put into tender box, the same shall be submitted by the tenderer by hand to the designated officers of BRBNMPL, as indicated in clause 1 of NIT. The officer receiving the tender will give the tenderer an official receipt duly signed with date and time.
- 21.2 The tenderers must ensure that they deposit their tenders not later than the closing time and date specified for submission of tenders. In the event of the specified date for submission of tender falls on / is subsequently declared a holiday or closed day for BRBNMPL, the tenders will be received up to the appointed time on the next working day.

22. Late Tender

A tender, which is received after the specified date and time for receipt of tenders will be treated as "late" tender and will be ignored.

23. Alteration and Withdrawal of Tender

- 23.1 The tenderer, after submitting its tender, is permitted to alter / modify its tender so long as such alterations / modifications are received duly signed, sealed and marked like the original tender, within the deadline for submission of tenders. Alterations / modifications to tenders received after the prescribed deadline will not be considered.

Tender- Construction of Class Room at Pindrakuli Primary School of Salboni Block, Paschim Midnapore.

- 23.2 No tender should be withdrawn after the deadline for submission of tender and before expiry of the tender validity period. If a tenderer withdraws the tender during this period, it will result in forfeiture of the earnest money furnished by the tenderer in its tender besides other sanctions by BRBNMPL.

E TENDER OPENING

24. Opening of Tenders

- 24.1 BRBNMPL will open the tenders at the specified date and time and at the specified place as indicated in clause 1 of NIT. In case the specified date of tender opening falls on / is subsequently declared a holiday or closed day for BRBNMPL, the tenders will be opened at the appointed time and place on the next working day.
- 24.2 Authorized representatives of the tenderers, who have submitted tenders on time may attend the tender opening, provided they bring with them letters of authority as per the format in SBD XIV from the corresponding tenderers. The tender opening official(s) will prepare a list of the representatives attending the tender opening. The list will contain the representatives' names & signatures and corresponding tenderers' names and addresses.
- 24.3 During the tender opening, the tender opening official(s) will read the salient features of the tenders like description of the work to be executed, price, special discount if any, delivery period, whether earnest money furnished or not and any other special features of the tenders, as deemed fit by the tender opening official(s).
- 24.4 In the case of two-bid system mentioned in clause 20.8 above, the technical bids are to be opened in the first instance, at the prescribed time and date. These bids shall be scrutinized and evaluated by the competent committee / authority with reference to parameters prescribed in the tender document. Thereafter, in the second stage, the financial bids of only the technically acceptable offers (as decided in the first stage) shall be opened for further scrutiny and evaluation. Other financial bids would be returned unopened to the respective bidders under Registered AD/ Reliable Courier or any other mode with proof of delivery.

F SCRUTINY AND EVALUATION OF TENDERS

25. Basic Principle

Tenders will be evaluated on the basis of the terms & conditions already incorporated in the tender document, based on which tenders have been received and the terms, conditions etc. mentioned by the tenderers in their tenders. No new condition will be brought in while scrutinizing and evaluating the tenders.

Tender- Construction of Class Room at Pindrakuli Primary School of Salboni Block, Paschim Midnapore.

26. Preliminary Scrutiny of Tenders

- 26.1 The tenders will first be scrutinized to determine whether they are complete and meet the essential and important requirements, conditions etc. as prescribed in the tender document, The tenders, that do not meet the basic requirements, are liable to be treated as unresponsive and ignored.
- 26.2 The following are some of the important aspects, for which a tender may be declared unresponsive and ignored;
- a) Tender is unsigned.
 - b) Tenderer is not eligible.
 - c) Tender validity is shorter than the required period.
 - d) Required EMD has not been provided.
 - e) Tenderer has quoted for goods manufactured by a different firm without the required authority letter from that manufacturer.
 - f) Tenderer has not agreed to give the required performance security.
 - g) Goods offered are sub-standard, not meeting the required specification etc.
 - h) Tenderer has not agreed to essential condition(s) specially incorporated in the tender enquiry.
 - i) Against a schedule in the List of Requirement (incorporated in the tender enquiry), the Tenderer has not quoted for the entire requirement as specified in that schedule. (Example: In a schedule, it has been stipulated that the Tenderer will supply the equipment, install and commission it and also train BRBNMPL's operators for operating the equipment. The Tenderer has however, quoted only for supply of the equipment).

27. Minor Infirmary / Irregularity / Non-Conformity

If during the preliminary examination, BRBNMPL find any minor infirmity and/ or irregularity and/ or non-conformity in a tender, BRBNMPL may waive the same provided it does not constitute any material deviation and financial impact and, also, does not prejudice or affect the ranking order of the tenderers. Wherever necessary, BRBNMPL will convey its observation on such 'minor' issues to the tenderer by registered/ speed post etc. asking the tenderer to respond by a specified date. If the tenderer does not reply by the specified date or gives evasive reply without clarifying the point at issue in clear terms, that tender will be liable to be ignored.

28. Discrepancy in Prices

- 28.1 If, in the price structure quoted by a tenderer, there is discrepancy between the unit price and the total price (which is obtained by multiplying the unit price by the quantity), the unit price shall prevail and the total price corrected accordingly, unless BRBNMPL feels that the tenderer has made a mistake in placing the decimal point in the unit price, in which case the total price as quoted shall prevail over the unit price and the unit price corrected accordingly.
- 28.2 If there is an error in a total price, which has been worked out through addition and / or subtraction of subtotals, the subtotals shall prevail and the total corrected; and
- 28.3 If there is a discrepancy between the amount expressed in words and figures, the amount in words shall prevail, subject to sub clause 28.1 and 28.2 above.

Tender- Construction of Class Room at Pindrakuli Primary School of Salboni Block, Paschim Midnapore.

28.4 If, as per the judgment of BRBNMPL, there is any such arithmetical discrepancy in a tender, the same will be suitably conveyed to the tenderer by registered / speed post. If the tenderer does not agree to the observation of BRBNMPL, the tender is liable to be ignored.

29. Discrepancy between original and copies of Tender (Not Applicable)

In case any discrepancy is observed between the text etc. of the original copy and that in the other copies of the same tender set, the text etc. of the original copy shall prevail. Here also, BRBNMPL will convey its observation suitably to the tenderer by register / Speed post and, if the tenderer does not accept BRBNMPL's observation, that tender will be liable to be ignored.

30. Clarification of Bids

During evaluation and comparison of bids, BRBNMPL may, at its discretion ask the bidder or clarification of its bid. The clarification should be received within 7 days from the bidder from date of receipt of such request. The request for clarification shall be in writing and no change in prices or substance of the bid shall be sought, offered or permitted. No post bid clarification at the initiative of the bidder shall be entertained.

31. Qualification / Eligibility Criteria

Tenders of the tenderers, who do not meet the required qualification / eligibility criteria prescribed in Section IX, will be treated as unresponsive and will not be considered further.

32. Conversion of tender currencies to Indian Rupees

In case the tender document permits the tenderers to quote their prices in different currencies, all such quoted prices of the responsive tenderers will be converted to a single currency viz., Indian Rupees for the purpose of equitable comparison and evaluation, as per the B.C. selling exchange rates established by the State Bank of India for similar transactions, as on the date of tender opening.

33. Schedule-wise Evaluation

In case the List of Requirements contains more than one schedule, the responsive tenders will be evaluated and compared separately for each schedule. The tender for a schedule will not be considered if the complete requirements prescribed in that schedule are not included in the tender. However, as already mentioned in GIT sub clause 12.2, tenderers have the option to quote for any one or more schedules and offer discounts for combined schedules. Such discounts, wherever applicable, will be taken into account to determine the tender or combination of tenders offering the lowest evaluated cost for BRBNMPL in deciding the successful tenderer for each schedule, subject to that tenderer(s) being responsive.

Tender- Construction of Class Room at Pindrakuli Primary School of Salboni Block, Paschim Midnapore.

34. Comparison on CIF Destination Basis

Unless mentioned otherwise in Section-III — Special Instructions to Tenderers and Section-XII — List of Requirements, the comparison of the responsive tenders shall be on CIF destination basis, duly delivered, commissioned, etc. as the case may be.

35. Additional Factors and Parameters for Evaluation and Ranking of Responsive Tenders

35.1 Further to GIT Clause 33 above, BRBNMPL's evaluation of a tender will include and take into account the following:

- a) In the case of goods manufactured in India or goods of foreign origin already located in India, sales tax & other similar taxes and excise duty & other similar duties, which will be contractually payable (to the tenderer), on the goods if a contract is awarded on the tenderer; and
- b) In the case of goods of foreign origin offered from abroad, customs duty and other similar import duties/ taxes, which will be contractually payable (to the tenderer) on the goods if the contract is awarded on the tenderer. **(Not applicable)**

35.2 BRBNMPL's evaluation of tender will also take into account the additional factors, if any, incorporated in SIT in the manner and to the extent indicated therein.

35.3 As per policies of the Government from time to time, the contractor reserves its option to give price preference to Small Scale Industries in comparison to the large scale Industries. This price preference cannot however be taken for granted and every endeavor need to be made by such firms to bring down cost and achieve competitiveness. **(Not applicable)**

35.4 If the tenders have been invited on variable price basis, the tenders will be evaluated, compared and ranked on the basis of the position as prevailing on the day of tender opening and not on the basis of any future date.

36. Tenderer's capability to perform the contract

36.1 BRBNMPL, through the above process of tender scrutiny and tender evaluation, will determine to its satisfaction whether the tenderer, whose tender has been determined as the lowest evaluated responsive tender is eligible, qualified and capable in all respects to perform the contract satisfactorily. If, there is more than one schedule in the List of Requirements, then, such determination will be made separately for each schedule.

36.2 The above mentioned determination will, inter-alia, take into account the tenderer's financial, technical and production capabilities for satisfying all the requirements of BRBNMPL as incorporated in the tender document. Such determination will be based upon scrutiny and examination of all relevant data and details submitted by the tenderer in its tender as well as such other allied information as deemed appropriate by BRBNMPL.

Tender- Construction of Class Room at Pindrakuli Primary School of Salboni Block, Paschim Midnapore.

37. Cartel Formation / Pool Rates

Cartel formation or quotation of Pool/ Co-ordinated rates, leading to 'Appreciable Adverse Effect on Competition' (AAEC) as identified in Competition Act, 2002, as amended by Competition (Amendment) Act, 2007, would be considered as a serious misdemeanor and would be dealt accordingly as per Clause 44 below.

38. Negotiations

Normally there would be no price negotiations but BRBNMPL reserves its right to negotiate with the lowest acceptable bidder (L1), who is technically cleared/ approved for supply of bulk quantity and on whom the contract would have been placed but for the decision to negotiate, under special circumstances in accordance with CVC guidelines. i.e. Normally there should be no negotiation. Selection of contractors by negotiations should be a rare exception rather than the rule and may be resorted to only in the exceptional circumstances under the following circumstances:--

- i. Where the procurement is done on proprietary basis.
- ii. Items to be procured are supplied by only limited sources of supply.
- iii. Items where there is suspicion of cartel formation.

39. Contacting BRBNMPL

- 39.1. From the time of submission of tender to the time of awarding the contract, if a tenderer needs to contact BRBNMPL for any reason relating to this tender enquiry and / or its tender, it should do so only in writing.
- 39.2. It will be treated as a serious misdemeanor in case a tenderer attempts to influence BRBNMPL's decision on scrutiny, comparison, evaluation and award of the contracts. In such a case the tender of the tenderer shall be liable for rejection in addition to appropriate administrative actions being taken against that tenderer, as deemed fit by BRBNMPL, in terms of clause 44 of GIT.

G AWARD OF CONTRACT

40. BRBNMPL's Right to Accept any Tender and to Reject any or All Tenders BRBNMPL reserves the right to accept in part or in full any tender or reject any tender without assigning any reason or to cancel. The tendering process and reject all tenders at any time prior to award of contract, without incurring any liability, whatsoever to the affected tenderer or tenderers.

40. Award Criteria

Subject to GIT clause 36 above, the contract will be awarded to the lowest evaluated responsive tenderer decided by BRBNMPL in terms of GIT Clause 34.

Tender- Construction of Class Room at Pindrakuli Primary School of Salboni Block, Paschim Midnapore.

42. Variation of Quantities at the Time of Award

No variation of quantities at the time of awarding the contract.

43. Parallel Contracts

BRBNMPL reserves its right to conclude Parallel contracts, with more than one bidder (for the same tender). If this is foreseen at the time of Tendering, a clause would be included in SIT giving further details.

44. Serious Misdemeanors

44.1. Following would be considered serious misdemeanors:

- i. Submission of misleading / false/ fraudulent information/ documents by the bidder in their bid.
- ii. Submission of fraudulent / unencashable Financial Instruments stipulated under Tender or Contract Condition.
- iii. Violation of Code of Ethics laid down in Clause 32 of the GCC.
- iv. Cartel formation or quotation of Pool / coordinated rates leading to "Appreciable Adverse Effect on Competition" (AAEC) as identified under the Competition Act, 2002.
- v. Deliberate attempts to pass off inferior goods or short quantities.
- vi. Violation of Fall Clause by Rate Contract holding Firms.
- vii. Attempts to influence BRBNMPL's Decisions on scrutiny, comparison, evaluation and award of Tender.

44.2. Besides, suitable administrative actions, like rejecting the offers or delisting of registered firms, BRBNMPL would ban/ blacklist Tenderers committing such misdemeanor, including declaring them ineligible to be awarded BRBNMPL contracts for indefinite or for a stated period.

45. Notification of Award

45.1 Before expiry of the tender validity period, BRBNMPL will notify the successful tenderer(s) in writing, by registered / speed post or by fax/email / telex/ cable (to be confirmed by registered / speed post) that its tender for goods & services, which have been selected by BRBNMPL, has been accepted, also briefly indicating therein the essential details like description, specification and quantity of the goods & services and corresponding prices accepted.

45.2 The notification of award shall constitute the conclusion of the contract.

46. Issue of Contract

46.1 Within seven working days of receipt of performance security, BRBNMPL will send the contract form (as per Section XIII) duly completed and signed, in duplicate, to the successful tenderer by registered / speed post. **(Not applicable for this Tender)**

46.2 Within seven days from the date of issue of the contract, the successful tenderer will return the duplicate copy of the contract, duly signed and dated, to BRBNMPL by registered / speed post.

Tender- Construction of Class Room at Pindrakuli Primary School of Salboni Block, Paschim Midnapore.

- 47. Non-receipt of Performance Security and Contract by BRBNMPL.**
Failure of the successful tenderer in providing performance security within 21 days of receipt of notification of award and / or returning contract copy duly signed in terms of GIT clauses 45 and 46 above shall make the tenderer liable for forfeiture of its EMD and, also, for further sanctions by BRBNMPL against it.
- 48. Return of EMD**
The earnest money of the successful tenderer and the unsuccessful tenderers will be returned to them without any interest, whatsoever, in terms of GIT Clause 18.6.
- 49. Publication of Tender Result**
The name and address of the successful tenderer(s) receiving the contract(s) will be mentioned in the notice board/ bulletin/ web site of BRBNMPL.

Part II: Additional General Instructions Applicable to Specific Types of Tenders:

[NOT APPLICABLE FOR THIS TENDER]

- 50. Rate Contract Tenders:**
- 51. Prequalification Bidding**
- 51.1 Prequalification Bidding is for short listing of qualified Bidders who fulfill the Prequalification criteria as laid down in SIT or in Section IX of SBD — "Qualification Criteria" for procurement of Goods or Services as listed in Section VI of SBD — "List of Requirements". Short listed Bidders would be informed of their qualification and short listing in accordance with the stipulations laid down in the SIT. Unless otherwise stipulated in the SIT the PQB short listing would be valid only till the next procurement tender. Further conditions will be elaborated in the SIT.
- 51.2 If stipulated in the SIT, only these short listed qualified bidders would be invited to participate in the Procurement of the requirements. Otherwise SIT may also indicate that instead of floating a separate PQB tender, it may be combined with the Procurement Tender, as a three bid tender. Initially the first Packet containing PQB would be opened and evaluation would be done. Thereafter the rest of tender would be handled as a two bid system for only those bidders who succeed in PQB.
- 52. Tenders involving Samples**
- 52.1 Normally no sample would be called along with the offer for evaluation.
- 52.2 Purchaser's Samples: If indicated in the SIT, A Purchaser's sample may be displayed to indicate required characteristics over and above the Specifications for perusal of the bidders. Name and Designation of the Custodian, Place, Dates and Time of inspection of Purchaser's sample will be indicated in the SIT. The supplies in the contract will have to meet the indicated required characteristics for which the Purchaser's sample was displayed, besides meeting the specification listed in Section VII — "Technical Specifications" of the SBD. He would be issued a sealed Purchaser's sample for the purpose at the time of award of the contract.

Tender- Construction of Class Room at Pindrakuli Primary School of Salboni Block, Paschim Midnapore.

- 52.3 **Pre-Production Samples:** If stipulated in SIT, successful contractor would be required to submit a Pre-Production sample(s) to the Inspecting Officer/ or the nominated authority mentioned in the contract within the time specified therein. If the Contractor is unable to do so, he must apply immediately to the Office issuing the acceptance of tender for extension of time stating the reasons for the delay. If the Purchaser is satisfied that a reasonable ground for an extension of time exists, he may allow such additional time as he considers to be justified (and his decision shall be final) with or without alteration in the delivery period stipulated in the contract and on such conditions as he deems fit. In the event of the failure of the Contractor to deliver the pre-production sample by the date specified in the acceptance of tender or any other date to which the time may be extended as aforesaid by the Purchaser or of the rejection of the sample, the Purchaser shall be entitled to cancel the contract and, if so desired, purchase or authorize the purchase of the stores at the risk and cost of the Contractor {unless specified otherwise in the SIT). In such an event, in case of Security Items where urgency develops due to such delays, BRBNMPL reserves its right to procure not more than one year's requirement against this "Risk & Cost" tender from existing pre-qualified and security cleared firms. Bulk production and supply will only be allowed if this sample(s) pass the Tests laid down in the Section VIII "Quality Control Requirements" in the SBD.
- 52.4 **Testing of Samples:** Tests, procedures and testing laboratories for testing samples would be detailed in the Section VIII — "Quality Control Requirements" in the SBD.
- 52.5 **Validation/ Prolonged Trials:** If specified in SIT or in the Section VIII — "Quality Control Requirements" in the SBD, pre-production samples may have to undergo validation or extended trial before their performance can be declared satisfactory.
- 52.6 Parameters Settings and duration of Validation Tests would be indicated in the Section VIII — "Quality Control Requirements" in the SBD. It would also stipulate the period or event marking end of validation trials. It would also be indicated therein whether the Permission to start bulk production will have to wait full validation or it can go on in parallel.
53. **Expression of Interest (EOI) Tenders: NOT APPLICABLE FOR THIS TENDER**
54. **Tenders for Disposal of Scrap: NOT APPLICABLE FOR THIS TENDER**
55. **Development and Indigenization Tenders: NOT APPLICABLE FOR THIS TENDER**
- 55.1 Already developed firms or firms who have already received development orders for the item (with whatever results) would not be considered in such tenders.
- 55.2 If specified in SIT the contract documents may be issued free of cost, and submission of earnest money deposit and security deposit may be relaxed.
- 55.3 If specified in SIT, The Tenderers may quote separately for: -

Tender- Construction of Class Room at Pindrakuli Primary School of Salboni Block, Paschim Midnapore.

- i. Price / rate for bulk supply of item in development / indigenization supplies and
 - ii. Separately, cost of development including cost of pre-production samples. Firms would be paid only for the number of samples specified in the Tender. If he has to manufacture more samples due to failure of earlier one, he would not be paid for it.
- 55.4 L1 would be determined on the basis of rate of item quoted including reference to total cost of the development cost (including the cost of prototype) plus the notional total cost of quantities that will be required over next three years, wherever applicable.
- 55.5 Development contracts may, as far as feasible, be concluded with two or more contractors in parallel.
- 55.6.1 The ratio of splitting of the supply order between various development agencies / firms in cases of parallel development, including criteria thereof, would be specified in the SIT.
- 55.6.2 However, in case the requirement is meager and complex technology is involved, or quantity of the equipment/ spares is limited/small/ uneconomic if distributed between two vendors, the entire order could be placed upon the L1 vendor only.
- 55.7 If specified in SIT, Advance and Intermediate Payment to Suppliers may be allowed.
- 55.9 Quantity for Development Commitment
In Next three years, after the newly developed firm is able to successfully complete Development orders with +5% tolerances, 20% of annual quantity requirement may be reserved for Newly Developed firms.
- 55.10 Period of Development Commitment
A newly developed firm would be granted this facility till only three years after completing the initial Development order. However this facility is not a bar to the firm from competing with already established firms for quantities larger than 20% provided their prices and performance so warrant. Thereafter they would have to compete on equal terms with other already developed firms.

Tender- Construction of Class Room at Pindrakuli Primary School of Salboni Block, Paschim Midnapore.

Section III: Special Instructions to Tenderers (SIT)

The following Special Instructions to Tenderers will apply for this purchase. These special instructions will modify/ substitute/ supplement the corresponding General Instructions to Tenderers (GIT) incorporated in Section II. The corresponding GIT clause numbers have also been indicated in the text below:

In case of any conflict between the provision in the GIT and that in the SIT, the provision contained in the SIT shall prevail.

(Clauses of GIT listed below include a possibility for variation in their provisions through SIT. There could be other clauses in SIT as deemed fit.)

Sl. No.	GIT Clause No.	Topic	SIT Provision
1	4	Eligible Goods and Services (Origin of Goods)	As applicable
2	8	Prebid Conference	Not applicable
3	9	Time Limit for receiving request for clarification of Tender Documents	As applicable
4	11.2	Tender Currency	As applicable
5	12.11	Applicability of Octroi and Local taxes	As applicable
6	14	Firm Price / Variable Price	As applicable
7	19	Tender Validity	As applicable
8	20.4	Number of Copies of Tenders to be submitted	Single copy
9	20.9	E-Procurement	Not applicable
10	35.2	Additional Factors for Evaluation of Offers	As applicable
11	43	Parallel Contracts	Not applicable for this tender
12	51.1, 51.2	PQB Tenders	Not applicable
13	52.1, 52.3, 52.5, 55	Tenders involving Purchaser's and Pre- Production Samples	Not applicable

Tender- Construction of Class Room at Pindrakuli Primary School of Salboni Block, Paschim Midnapore.

ADDITIONAL SPECIAL INSTRUCTIONS TO TENDERERS: -

1. SCOPE OF WORK:

The scope of work shall include:

Construction of Class Room at Pindrakuli Primary School of Salboni Block, Paschim Midnapore. This involves Brickwork, RCC, PCC, IPS flooring, Plastering, Painting and wood work for door etc. as per drawing issued with tender documents. The quantity mentioned in BOQ against each individual item is tentative and likely to be changed as per site requirement. The successful contractor has to visit the site before commencement of work and procure the materials as per the site condition. Payment shall be made as per actual certified work and no payment will be made against the extra quantity brought to the site.

2. TIME SCHEDULE:

The total work should be completed within **four months** from the date of issue of the work order/LOI. Since time is the essence of the contract, contractor should mobilize all the resources to complete the work in time. On placement of work order in case the contractor fails to start the job within ten days time, BRBNMPL reserves the right to cancel the contract and EMD amount will be forfeited.

3. CONTRACT PRICE:

- a) The quoted price shall be fixed; firm & binding and no escalation in price on any account shall be admissible during the contract period.
- b) The contract price shall be inclusive of all taxes including service Tax, VAT, duties, levies etc. all-inclusive.
- c) Statutory deductions shall be made at source as per prevailing rules.
- d) Service tax will be paid at actuals as per prevailing rate.

4. VALIDITY OF QUOTATION:

Tender and the price/rate quoted shall remain valid for acceptance for a period of **4 (four) months** from the last date of receipt of tenders, period of which may be extended by mutual consent and the tenderer shall not cancel or withdraw the tender during this period.

5. SECURITY DEPOSIT:

Within twenty one days after the issue of Work Order by BRBNMPL, the Contractor shall furnish Security Deposit to BRBNMPL for an amount equal to 10% of the Order value less EMD, which will be retained for Defect Liability Period (DLP) of one year from the date of successful completion of the work. Please refer GCC Clause 6, Under Section-IV.

Tender- Construction of Class Room at Pindrakuli Primary School of Salboni Block, Paschim Midnapore.

6. EARNEST MONEY DEPOSIT:

E.M.D.: An EMD of **Rs 21,500/- (Rupees Twenty one thousand Five hundred only)** is payable in the form of Demand Draft / Banker's Cheque / Fixed Deposit drawn in favour of Bharatiya Reserve Bank Note Mudran Pvt. Ltd., payable at par at the State Bank of India, Salboni (Code No.3558) drawn from any Branch of SBI in India. If drawn from any Associate Bank of SBI or any other Scheduled Commercial Bank in India, it should be payable at par at Midnapore. Bid without EMD may be liable for rejection. For successful bidder, EMD amount will be converted into Security deposit & for other unsuccessful bidders, EMD will be virtually returned after finalization of contract. In any case no interest will be paid.

7. METHOD OF EVALUATION:

- a) BRBNMPL reserves the right of accepting the whole or any part of the tender or cancels the tender as a whole or any part without assigning any reasons. BRBNMPL shall evaluate the bids to determine whether they are complete, whether any computational errors have been made, whether required sureties has been furnished, whether documents have been properly signed, whether the bids are generally in order.
- b) The evaluation of price bid shall be based normally on quoted price for the work as per scope of work & on L1 basis.

8. MAN POWER / INDEMNITY:

You shall employ qualified and experienced personnel for the work. You shall be responsible for any damage that may be caused to the existing system due to (i) Lack of knowledge, (ii) Wrong operation, (iii) Mishandling, (iv) Sabotage etc.. In such cases, you will be responsible for compensating any damage/accident to men / material during execution of work as per prevailing labour rules.

9. MATERIALS:

All the materials used should be of highest quality, manufactured by reputed company and purchased from authorized dealer. The contractor shall provide documentary evidence to this effect, if called for. The materials used for the work by you are liable for rejection at any stage if found of substandard / poor quality.

10. SAFETY & INSURANCE:

The contractor will insure all his employees against injury/death while on duty and will indemnify the BRBNMPL against any claim arising out of any accident, injury or death during the course of their duty. The BRBNMPL holds no liability in case of any accident or death during working in the selected sites. You should employ physically fit personnel for carrying out all jobs specified in this tender. Special care should be taken during the execution of the said work, which involves Brick foundation, Brick wall, Plastering, Painting, Construction of soak well etc.

Tender- Construction of Class Room at Pindrakuli Primary School of Salboni Block, Paschim Midnapore.

11. SIGNING AND SEALING OF TENDER:

This is in continuation of GIT Clause No. 20, quotation in two parts consisting of –

Techno-commercial Bid– In the prescribed format as per the following, if applicable

1. Section I - Notice Inviting Tender (NIT)
2. Section II - General Instructions to Tenderers (GIT)
3. Section III - Special Instructions to Tenderers (SIT)
4. Section IV -General Conditions of Contract (GCC)
5. Section V - Special Conditions of Contract (SCC)
6. Section VI - Questionnaire
7. Section VII - Technical Specifications
8. Section VIII - Quality Control Requirements
9. Section IX — Qualification/ Eligibility Criteria
10. Section X - Tender Form
11. **Section XI - Price Schedule (UN-PRICED)**
12. Section XII - List of Requirements
13. Section XIII - Bank Guarantee Form for Performance Security
14. Section XIV - Letter of Authority for attending Bid opening
15. Section XV - Proforma of Bills for Payment

Price Bid (Financial Bid) - In the prescribed format duly filled, signed and stamped as per the following

1. Section XI - Price Schedule (PRICED VERSION)

All the pages of tender documents shall be duly signed, stamped & submitted by the tenderer along with Techno-Commercial bid as a token of having read and accepted all the terms & conditions. An **Un-priced version of price schedule (section XI) duly signed & stamped to be included in the techno-commercial bid.**

12. PRE-TENDER ORIENTATION:

It is requested to visit the site to assess the quantum of work involved, prior to submitting the tender, during working hours in the CSR Section Office. Bidder may contact Assistant Manager of CSR Section (Intercom phone: 4311, 4313).

13. TOOLS, TACKLES & SAFETY EQUIPMENTS:

All the Tools & Tackles, measuring & testing equipment, personnel protective equipment (safety shoes, helmet etc.) etc. required for carrying out the subject work have to be supplied by the contractor.

14. TRANSPORT:

Transportation of man and material will be under the scope of this contract without any additional cost.

Tender- Construction of Class Room at Pindrakuli Primary School of Salboni Block, Paschim Midnapore.

15. STATUTORY REQUIREMENT:

- a) The contractor shall have to fulfill all the statutory requirements as per the provisions of law i.e. Factory Act, Contract Labour Act, etc and shall, by periodical substitution / rotation of manpower, indemnify BRBNMPL from any claims in future or due to any breach of the statutory requirements. The BRBNMPL, as a principal employer, shall enforce the provisions of these Acts.
- b) Any untoward incident arising out of improper supervision or inadequate safety measures will be the sole responsibility of the contractor. The Contractor shall conform to all the Labour Laws and shall remain solely responsible for the obligation under the relevant statutory provisions.
- c) The contractors should properly maintain all necessary first aid kits in the work area and ensure that all its employees are adequately trained in administering first aid in case of emergencies.
- d) The contractor should ensure that all his employees are adequately trained in the use of Firefighting equipment maintained in the work area.

16. CO-ORDINATING AUTHORITY:

The Asst. General Manager (CSR) or the officer (Assistant Manager) authorized by him shall be the Co-ordinating Officer. The contractor has to report to such authority and perform the work in close coordination with such authority.

17. LABOUR LAW:

The contractor shall be responsible to fulfill all the obligations under various labour laws such as Contract Labour (Regulation & abolition) Act, 1970, The Minimum Wages Act, 1948, Payment of Wages Act, 1936, The Payment of Bonus Act, 1965, The ESI Act, 1948 The Employees Provident Fund and Miscellaneous Provision Act, 1952, The Workmen Compensation Act, 1923 and other applicable laws. The contractor should arrange to cover all his workmen of appropriate Insurance coverage to address the liability under the workmen compensation Act, 1923 during the full tenure of the contract and shall submit a copy of the Insurance to the company before commencement of the work.

18. INDEMNITY:

The contractor shall indemnify the company BRBNMPL from all liability, claims, cost of expenses, taxes and assessment including penalties, punitive damages attorney's fees and court costs which are or may be required with respect to any breach of the contractor's responsibility including those imposed by statutes, ordinance, laws rules regulations in respect of salaries, wedges and other compensations to all persons employed and engaged by the contractor or suppliers in connection with the performance by the contractor of any work covered in the Work Order.

Tender- Construction of Class Room at Pindrakuli Primary School of Salboni Block, Paschim Midnapore.

19. SECURITY:

Ours is a security organisation and the Govt. declares the premise as 'Prohibited Area' of West Bengal. Hence the contractor has to abide by the security rules of the Company and to instruct their employees accordingly.

20. ACCOMODATION:

No accommodation will be provided by BRBNMPL during the execution of the work.

21. COUNTER CONDITIONS:

No counter conditions shall be admitted/ accepted. Bids with counter conditions are liable to be rejected. Price bids with conditional prices are liable to be rejected. Any deviations in technical/commercial specification should not to be mentioned / quoted in the price bid format / envelope; otherwise the bid will be rejected.

22. OTHER TERMS AND CONDITIONS:

- a) Contractor has to ensure timely completion of work and schedule the work accordingly in due consultation with the school Authority / Local Authority as applicable. Contractor is advised to consult with School Authority / Local Authority as applicable as regard working hours and necessary source for electricity and water for execution of the job.
- b) In the event of breach of any of the above mentioned conditions, incompetence, and breach of trust, misconduct or any other reason that is against the interest of BRBNMPL, BRBNMPL reserves the right to cancel the contract without any financial compensation or assigning any reason thereof.
- c) The BRBNMPL have privy of contract with you only and will give instructions to you and shall not be responsible for the conditions of employment of your staff deployed at your site for performance of the contract. However, due to obvious security reasons, you must ensure that the staff deployed by you must adhere to all rules & regulations and security restrictions as prescribed by BRBNMPL from time to time.
- d) In case of any loss / losses are caused to BRBNMPL on account of non-fulfillment and/or non-compliance of any obligations, statutory or otherwise, on your part, BRBNMPL shall have full right to make adjustment for the said losses from your bills payable to you.
- e) You will be free to work anywhere else or to undertake any contract and can also rotate your staff provided that you will remain responsible to BRBNMPL for proper and efficient execution of the jobs entrusted to you.
- f) **Necessary electricity and water** for construction shall be drawn by contractor from nearby source at his own cost and the contractor shall make all necessary arrangements for such connections and storage.

Section IV: General Conditions of Contract (GCC)

Part I: General Conditions of Contract applicable to all types of Tenders

1. Definitions; Interpretation and Abbreviations: In the contract, unless the context otherwise requires:

1.1 Definitions and Interpretation:

- (i) "Contract" means the letter or memorandum communicating to the Contractor the acceptance of this tender and includes "Intimation of Award" of his tender; "Contract" includes and Bid Invitation, Instructions to Tenderers, Tender, Acceptance of Tender, General Conditions of Contract, Schedule of Requirements, particulars and the other conditions specified in the acceptance of tender and includes a repeat order which has been accepted or acted upon by the Contractor and a formal agreement, if executed;
- (ii) "Contractor" or "Supplier" means the individual or the firm supplying the goods and services. The term includes his employees, agents, successors, authorized dealers, stockiest and distributors. Other homologous terms are: Vendor, Firm, Manufacturer, OEM etc.;
- (iii) "Drawing" means the drawing or drawings specified in or annexed to the Specifications;
- (iv) "Government" means the Central Government or a State Government as the case may be;
- (v) The "Inspecting Officer" means the person, or organisation specified in the contract for the purpose of inspection of stores of work under the contract and includes his / their authorised representative;
- (vi) "Purchase Officer" means the officer signing the acceptance of tender and includes any officer who has authority to execute the relevant contract on behalf of the Purchaser;
- (vii) The "Purchaser" means BRBNMPL — the organization purchasing goods and services as incorporated in the documents;
- (viii) "Signed" includes stamped, except in the case of an acceptance of tender or any amendment thereof;
- (ix) "Test" means such test as is prescribed by the particulars or considered necessary by the Inspecting Officer whether performed or made by the Inspecting Officer or any agency acting under the direction of the Inspecting Officer;
- (x) The delivery of the stores shall be deemed to take place on delivery of the stores in accordance with the terms of the contract, after approval by the Inspecting Officer if so provided in the contract —
 - a. The consignee at his premises; or
 - b. Where so provided, the interim consignee at his premises; or
 - c. A carrier or other person named in the contract for the purpose of transmission to the consignee: or
 - d. The consignee at the destination station in case of contract stipulating for delivery of stores at destination station.
- (xi) "Writing" or "Written" includes matter either in whole or in part, in manuscript, typewritten, lithographed, cyclostyled, photographed or printed under or over signature or seal, as the case may be.
- (xii) Words in the singular include the plural and vice-versa.
- (xiii) Words importing the masculine gender shall be taken to include the feminine gender and words importing persons shall include any company or association or body of individuals, whether incorporated or not.

Tender- Construction of Class Room at Pindrakuli Primary School of Salboni Block, Paschim Midnapore.

- (xiv) The heading of these conditions shall not affect the interpretation or construction thereof.
- (xv) Terms and expression not herein defined shall have the meanings assigned to them in the Indian Sale of Goods Act, 1930 (as amended) or the Indian Contract Act, 1872 (as amended) or the General Clauses Act, 1897 (as amended) as the case may be.
- (xvi) PARTIES: The parties to the contract are the "Contractor" and the "Purchaser", as defined above;
- (xvii) "Tender" means quotation / bid received from a firm / supplier.
- (xviii) "Goods" means the articles, material, commodities, livestock, furniture, fixtures, raw material, spares, instruments, machinery, equipment, industrial plant etc. which the supplier is required to supply to BRBNMPL under the contract. Other homologous terms are: Stores, Materials etc.
- (xix) "Services" means services allied and incidental to the supply of goods, such as transportation, installation, commissioning, provision of technical assistance, training, after sales service, maintenance service and other such obligations of the supplier covered under the contract.
- (xx) "Earnest Money Deposit" (EMD) means monetary guarantee to be furnished by a Tenderer along with its tender.
- (xxi) "Performance Security" means monetary guarantee to be furnished by the successful Tenderer for due performance of the contract placed on it. Performance Security is also known as Security Deposit or Performance Bank Guarantee.
- (xxii) "Consignee" means the person to whom the goods are required to be delivered as specified in the Contract. If the goods are required to be delivered to a person as an interim consignee for the purpose of dispatch to another person as provided in the Contract then that "another" person is the consignee, also known as ultimate consignee.
- (xxiii) "Specification" or "Technical Specification" means the drawing / document/ standard that prescribes the requirement to which product or service has to conform.
- (xxiv) "Inspection" means activities such as measuring, examining, testing, analyzing, gauging one or more characteristics of the product or service and comparing the same with the specified requirement to determine conformity.
- (xxv) "Day" means calendar day.

1.2 Abbreviations:

"AAEC"	means "Appreciable Adverse Effect on Competition" as per Competition Act
"BG"	means Bank Guarantee
"BL or B/L"	means Bill of Lading
"CD"	means Custom Duty
"CIF"	means Cost, Insurance and Freight Included
"CMD"	means Chairman and Managing Director
"CPSU"	means Central Public Sector Undertaking
"CST"	means Central Sales Tax
"DDO"	means Direct Demanding Officer in Rate Contracts
"DGS&D"	means Directorate General of Supplies and Disposals
"DP"	means Delivery Period
"ECS"	means Electronic clearing system

Tender- Construction of Class Room at Pindrakuli Primary School of Salboni Block, Paschim Midnapore.

"ED"	means Excise Duty
EMD	means Earnest money deposit
"EOI"	means Expression of Interest (Tendering System)
"ERV"	means Exchange rate variations
"FAS"	means Free alongside shipment
"FOB"	means Freight on Board
"FOR"	means Free on Rail
"GCC"	means General Conditions of Contract
GIT	means General Instructions to Tenderers
GST	means Goods and Services Tax which will replace Sales Tax
"H1, H2 etc"	means First Highest, Second Highest Offers etc in Disposal Tenders
Incoterms	means International Commercial Terms, 2000 (of ICC)
"L1, L2 etc"	means First or second Lowest Offer etc.
"LC"	means Letter of Credit
"LD or L/D"	means Liquidated Damages
"LSI"	means Large Scale Industry
"NIT"	means Notice Inviting Tenders.
"NSIC"	means National small industries corporation
"PQB"	means Pre qualification bidding
"PSU"	means Public Sector Undertaking
"PVC"	means Price variation clause
"RC"	means Rate contract
"RR or R/R"	means Railway Receipt
"SBD" or "T D"	means Standard Bid Document / Tender Document
"SCC"	means Special Conditions of Contract
"SIT"	means Special Instructions to Tenderers
"BRBNMPL"	means Bharatiya Reserve Bank Note Mudran Private Limited
"SS I"	means Small Scale Industry
"ST"	means Sales Tax
"VAT"	means Value Added Tax

2. Application

2.1. The General Conditions of Contract incorporated in this section shall be applicable for this purchase to the extent the same are not superseded by the Special Conditions of Contract (SCC) prescribed under Section V of this document.

2.2. General Conditions of the contract shall not be changed from one tender to other.

2.3. Other Laws and Conditions that will govern the Contract:

Besides GCC and SCC following conditions and Laws will also be applicable and would be considered as part of the contract:

Tender- Construction of Class Room at Pindrakuli Primary School of Salboni Block, Paschim Midnapore.

- i. Indian Contracts Act, 1872
- ii. Sale of Goods Act, 1930
- iii. Arbitration and Conciliation Act, 1996
- iv. Competition Act, 2002 as amended by Competition (Amendment Act), 2007
- v. Contractor's Tender Submissions including Revised Offer during Negotiations if any
- vi. Conditions in other parts of the Tender Documents
- vii. Correspondence including counter-offers if any; between the Contactor and BRBNMPL during the Tender Finalization
- viii. Notification of award and Contract Documents
- ix. Subsequent Amendments to the Contract

3. Use of contract documents and information

3.1. The contractor shall not, without BRBNMPL's prior written consent, disclose the contract or any provision thereof including any specification, drawing, sample or any information furnished by or on behalf of BRBNMPL in connection therewith, to any person other than the person(s) employed by the supplier in the performance of the contract emanating from this tender document. Further, any such disclosure to any such employed person shall be made in confidence and only so far as necessary for the purposes of such performance for this contract.

3.2. During the process of procurement of Security or Sensitive Machinery and Items, Tender Documents and the specifications/ drawings of such items would be issued only to Vendors having security clearance within the validity of such clearance and he shall maintain absolute secrecy and strictly control the number of copies and access to the documents and copies thereof, in addition to safeguards mentioned in sub-para above.

3.3. Further, the contractor shall not, without BRBNMPL's prior written consent, make use of any document or information mentioned in GCC sub-clause 3.1 above except for the sole purpose of performing this contract.

3.4. Except the contract issued to the contractor, each and every other document mentioned in GCC sub-clause 3.1 above shall remain the property of BRBNMPL and, if advised by BRBNMPL, all copies of all such documents shall be returned to BRBNMPL on completion of the contractor's performance and obligations under this contract.

4. Patent Rights – Not Applicable

4.1. The contractor shall, at all times, indemnify BRBNMPL, free of cost, against all claims which may arise in respect of goods & services to be provided by the contractor under the contract for infringement of any right protected by patent, registration of designs or trademarks. In the event of any such claim in respect of alleged breach of patent, registered designs, trademarks etc. being made against BRBNMPL, BRBNMPL shall notify the contractor of the same and the contractor shall, at his own expenses take care of the same for settlement without any liability to BRBNMPL.

Tender- Construction of Class Room at Pindrakuli Primary School of Salboni Block, Paschim Midnapore.

5. Country of Origin

5.1. All goods and services to be supplied and provided for the contract shall have the origin in India or in the countries with which the Government of India has trade relations.

5.2. The word "origin" incorporated in this clause means the place from where the goods are mined, cultivated, grown, manufactured, produced or processed or from where the services are arranged.

6. Performance Bond / Security

6.1. Within twenty-one days after the issue of notification of award by BRBNMPL, the contractor shall furnish performance security to BRBNMPL for an amount equal to ten per cent of the total value of the contract, valid up to sixty days after the date of completion of all contractual obligations by the contractor, including the warranty obligations.

6.2. The **Performance security** shall be denominated in Indian Rupees or in the currency of the contract and shall be in one of the following forms:

a. Account Payee Demand Draft or Fixed Deposit Receipt drawn on any commercial bank in India, in favour of the same of BRBNMPL as indicated in the clause 3 of NIT in reference to EMD.

b. **Bank Guarantee** issued by a commercial bank in India, in the prescribed form as provided in section XV of this document.

6.3. In the event of any loss due to Contractor's failure to fulfill its obligations in terms of the contract, the amount of the performance security shall be payable to BRBNMPL to compensate BRBNMPL for the same.

6.4. In the event of any amendment issued to the contract, the Contractor shall, within twenty-one days of issue of the amendment, furnish the corresponding amendment to the Performance Security (as necessary), rendering the same valid in all respects in terms of the contract, as amended.

6.5. Subject to GCC sub-clause 6.3 above, BRBNMPL will release the performance security without any interest to the contractor on completion of the contractor's all contractual obligations including the warranty obligations.

7. Technical Specifications and Standards

7.1. The Goods & Services to be provided by the contractor under this contract shall conform to the technical specifications and quality control parameters mentioned in 'Technical Specification' and 'Quality Control Requirements' under Sections VII and VIII of this document.

Tender- Construction of Class Room at Pindrakuli Primary School of Salboni Block, Paschim Midnapore.

8. Packing and Marking: (Not applicable for this Tender)

8.1. The packing for the goods to be provided by the supplier should be strong and durable enough to withstand, without limitation, the entire journey during transit including transshipment (if any), rough handling, open storage etc. without any damage, deterioration etc. As and if necessary, the size, weights and volumes of the packing cases shall also take into consideration, the remoteness of the final destination of the goods and availability or otherwise of transport and handling facilities at all points during transit upto final destination as per the contract.

8.2. The quality of packing, the manner of marking within & outside the packages and provision of accompanying documentation shall strictly comply with the requirements as provided in Technical Specifications and Quality Control Requirements under Sections VII and VIII and in SCC under Section V. in case the packing requirements are amended due to issue of any amendment to the contract, the same shall also be taken care of by the supplier accordingly.

8.3. Packing instructions: (Not applicable for this Tender)

Unless otherwise mentioned in the Technical Specification and Quality Control Requirements under Sections VII and VIII and in SCC under Section V, the supplier shall make separate packages for each consignee (in case there is more than one consignee mentioned in the contract) and mark each package on three sides with the following with indelible paint of proper quality:

- a) Contract number and date
- b) Brief description of goods including quantity
- c) Packing list reference number
- d) Country of origin of goods
- e) Consignee's name and full address and
- f) Supplier's name and address

9. Inspection and Quality Control

9.1. BRBNMPL and / or its nominated representative(s) will, without any extra cost to BRBNMPL, inspect and/ or test the ordered goods and the related services to confirm their conformity to the contract specifications and other quality control details incorporated in the contract. BRBNMPL shall inform the contractor in advance, in writing, BRBNMPL's programme for such inspection and, also the identity of the officials to be deputed for this purpose.

9.2. The Technical Specification and Quality Control Requirements incorporated in the contract shall specify what inspections and tests are to be carried out and, also, where and how they are to be conducted. If such inspections and tests are conducted in the premises of the contractor or its subcontractor(s), all reasonable facilities and assistance, including access to relevant drawings, design details and production data, shall be furnished by the contractor to BRBNMPL's inspector at no charge to BRBNMPL.

Tender- Construction of Class Room at Pindrakuli Primary School of Salboni Block, Paschim Midnapore.

9.3. If during such inspections and tests the contracted goods fail to conform to the required specifications and standards, BRBNMPL's inspector may reject them and the contractor shall either replace the rejected goods or make all alterations necessary to meet the specifications and standards, as required, free of cost to BRBNMPL and resubmit the same to BRBNMPL's inspector for conducting the inspections and tests again.

9.4. In case the contract stipulates pre-despatch inspection of the ordered goods at contractors' premises, the contractor shall put up the goods for such inspection to BRBNMPL's inspector well ahead of the contractual delivery period, so that BRBNMPL's inspector is able to complete the inspection within the contractual delivery period.

9.5. If the contractor tenders the goods to BRBNMPL's inspector for inspection at the last moment without providing reasonable time to the inspector for completing the inspection within the contractual delivery period, the inspector may carry out the inspection and complete the formality beyond the contractual delivery period at the risk and expense of the contractor. The fact that the goods have been inspected after the contractual delivery period will not have the effect of keeping the contract alive and this will be without any prejudice to the legal rights and remedies available to BRBNMPL under the terms & conditions of the contract.

9.6. BRBNMPL's contractual right to inspect, test and, if necessary, reject the goods after the goods' arrival at the final destination shall have no bearing of the fact that the goods have previously been inspected and cleared by BRBNMPL's inspector during pre-despatch inspection mentioned above.

9.7. Goods accepted by BRBNMPL and/ or its inspector at initial inspection and in final inspection in terms of the contract shall in no way dilute BRBNMPL's right to reject the same later, if found deficient in terms of the warranty clause of the contract, as incorporated under GCC Clause.

10. Terms of Delivery

10.1. Work shall be completed and handed over by the contractor in accordance with the terms as specified in the B.O.Q and technical specification of the contract.

11. Transportation of Goods: (Not applicable for this Tender)

11.1. The contractor shall not arrange part-shipments and/ or transshipment without the express / prior written consent of BRBNMPL.

11.2. Instructions for transportation of domestic goods including goods already imported by the supplier under its own arrangement: In case no instruction is provided in this regard in the SCC, the supplier will arrange transportation of the ordered goods as per its own procedure.

Tender- Construction of Class Room at Pindrakuli Primary School of Salboni Block, Paschim Midnapore.

12. Insurance:

(Not applicable for this Tender)

12.1 Unless otherwise instructed in the SCC, the supplier shall make arrangements for insuring the goods against loss or damage incidental to manufacture or acquisition, transportation, storage and delivery in the following manner.

12.2 In case of supply of domestic goods on CIF destination basis, the supplier shall be responsible till the entire stores contracted for arrive in good condition at destination. The transit risk in this respect shall be covered by the Supplier by getting the stores duly insured. The insurance cover shall be obtained by the Supplier in its own name and not in the name of BRBNMPL or its Consignee.

12.3 In the case of FOB and C&F offers for import of Goods, insurance shall be arranged by the Purchaser. However, the supplier must give sufficient notice to the Purchaser prior to the date of shipment, so that the Insurance Cover for the shipment can be activated. The Supplier must co-ordinate so as to ensure that the Shipment sails only with Insurance cover in place.

12.4 In case of Import of Goods, even in case where the insurance is paid by the Purchaser, and loss or damage shall be made good by the Contractor free of cost, without waiting for the settlement of insurance claim. The payment after settlement of insurance claim shall be reimbursed by the purchaser to the Contractor. It will be entirely the responsibility of the Contractor to make good loss/damage without waiting for settlement of insurance claim so that machine is commissioned within the time specified in the contract.

13. Spare parts:

(Not applicable for this Tender)

13.1. If specified in the List of Requirements and in the resultant contract, the supplier shall supply / provide any or all of the following materials, information etc. pertaining to spare parts manufactured and/ or supplied by the supplier:

a) The spare parts as selected by BRBNMPL to be purchased from the supplier, subject to the condition that such purchase of the spare parts shall not relieve the supplier of any contractual obligation including warranty obligations; and

Tender- Construction of Class Room at Pindrakuli Primary School of Salboni Block, Paschim Midnapore.

b) In case the production of the spare parts is discontinued:

- i. Sufficient advance notice to BRBNMPL before such discontinuation to provide adequate time to BRBNMPL to purchase the required spare parts etc., and
- ii. Immediately following such discontinuation, providing BRBNMPL, free of cost, the designs, drawings, layouts and specifications of the spare parts, as and if requested by BRBNMPL.

13.2. Supplier shall carry sufficient inventories to assure ex-stock supply of consumable spares for the goods so that the same are supplied to BRBNMPL promptly on receipt of order from BRBNMPL.

14. Incidental services: (Not applicable for this Tender)

14.1. Subject to the stipulation, if any, in the SCC (Section-V) and the Technical Specification (Section — VII), the supplier shall be required to perform any or all of the following services:

- a) Providing required jigs and tools for assembly, start-up and maintenance of the goods
- b) Supplying required number of operation & maintenance manual for the goods
- c) Installation and commissioning of the goods
- d) Training of BRBNMPL's operators for operating and maintaining the goods
- e) Providing after sales service during the tenure of the contract
- f) Providing maintenance service after expiry of the warranty period of the goods if so incorporated in the contract

14.2. Prices to be paid to the contractor by BRBNMPL for any of the required incidental services, if not already included in the contract price during the placement of the contract, shall be settled and decided in advance by BRBNMPL and the contractor. However, such prices shall not exceed the contemporary rates charged by the contractor to other customers for similar services.

15. Distribution of Despatch Documents for Clearance/ Receipt of Goods: (Not applicable)

15.1. The supplier shall send all the relevant despatch documents well in time to BRBNMPL to enable BRBNMPL to clear or receive (as the case may be) the goods in terms of the contract. Unless otherwise specified in the SCC, the usual documents involved and the drill to be followed in general for this purpose are as follows:

15.2. For Domestic Goods, including goods already imported by the supplier under its own arrangement Within 24 hours of despatch, the supplier shall notify BRBNMPL, consignee, and others concerned if mentioned in the contract, the complete details of despatch and also supply the following documents to them by registered post / speed post (or as instructed in the contract):

Tender- Construction of Class Room at Pindrakuli Primary School of Salboni Block, Paschim Midnapore.

- (a) Supplier's Invoice indicating, inter alia description and specification of the goods, quantity, unit price, total value;
- (b) Packing list;
- (c) Insurance certificate;
- (d) Railway receipt / Consignment note;
- (e) Manufacturer's guarantee certificate and in-house inspection certificate;
- (f) Inspection certificate issued by BRBNMPL's inspector
- (g) Expected date of arrival of goods at destination and
- (h) Any other document(s), as and if specifically mentioned in the contract.

15.3. For Imported Goods, within 3 days of dispatch, the supplier will Notify BRBNMPL, consignee and other concerned if mentioned in the contract, the complete details of dispatch and also supply the following documents to them by Courier (or as instructed in the Contract), besides advance intimation by Fax/ email: **(Not applicable for this contract)**

- (a) Clean on Board Airway Bill/Bill of Lading (B/L)
- (b) Original Invoice
- (c) Packing List
- (d) Certificate of Origin from Seller's Chamber of Commerce
- (e) Certificate of Quality and current manufacture from OEM
- (f) Dangerous Cargo Certificate, if any.
- (g) Insurance Policy of 110% if CIF/CIF contract.
- (h) Performance Bond / Warranty Certificate

16. Warranty

16.1 The contractor warrants that the goods supplied under the contract is new, unused and incorporate all recent improvements in design and materials unless prescribed otherwise by BRBNMPL in the contract. The contractor further warrants that the goods supplied under the contract shall have no defect arising from design, materials (except when the design adopted and / or the material used are as per BRBNMPL's specifications) or workmanship or from any act or omission of the supplier, that may develop under normal use of the supplied goods under the conditions prevailing in India.

16.2 This warranty shall remain valid for **twelve months** after the goods or any portion thereof as the case may be, have been delivered to the final destination and installed and commissioned at the final destination and accepted by BRBNMPL in terms of the contract or for fifteen months from the date of despatch from the supplier's premises for domestic goods (including goods already imported by the supplier under its own arrangement) or for eighteen months after the date of shipment from the port of loading in the source country for imported goods offered from abroad, whichever is earlier, unless specified otherwise in the SCC.

16.3. In case of any claim arising out of this warranty, BRBNMPL shall promptly notify the same in writing to the contractor.

Tender- Construction of Class Room at Pindrakuli Primary School of Salboni Block, Paschim Midnapore.

16.4. Upon receipt of such notice, the contractor shall, with all reasonable speed (or within the period, if specified in the SCC), repair or replace the defective goods or parts thereof, free of cost, at the ultimate destination. The contractor shall take over the replaced parts/ goods after providing their replacements and no claim, whatsoever shall lie on BRBNMPL for such replaced parts/ goods thereafter.

16.5. In the event of any rectification of a defect or replacement of any defective goods during the warranty period, the warranty for the rectified/ replaced goods shall be extended to a further period of twelve months from the date such rectified / replaced goods starts functioning to the satisfaction of BRBNMPL.

16.6. If the contractor, having been notified, fails to rectify / replace the defect(s) within a reasonable period (or within the period, if specified in the SCC), BRBNMPL may proceed to take such remedial action(s) as deemed fit by BRBNMPL, at the risk and expense of the contractor and without prejudice to other contractual rights and remedies, which BRBNMPL may have against the contractor.

16.7. WARRANTY PERIOD:

You shall provide warranty for satisfactory performance, minimum for **one year** from the date of satisfactory completion of works in all respect. You will be liable for any defect / deficiency arising out of substandard material / improper workmanship and replace / repair any defects within the above period at your own cost. You shall have to provide warranty certificate after successful completion of work. The security deposit shall only be released after expiry of warranty period.

17. Assignment

17.1. The contractor shall not assign, either in whole or in part, its contractual duties, responsibilities and obligations to perform the contract, except with BRBNMPL's prior written permission.

18. Sub Contracts

18.1. The contractor shall notify BRBNMPL in writing of all sub contracts awarded under the contract if not already specified in its tender. Such notification, in its original tender or later, shall not relieve the contractor from any of its liability or obligation under the terms and conditions of the contract.

18.2. Sub contract shall be only for bought out items and sub-assemblies.

18.3. Sub contracts shall also comply with the provisions of GCC Clause 5 ('Country of Origin").

19. Modification of contract

19.1. Once a contract has been concluded, the terms and conditions thereof will generally not be varied. However if necessary, BRBNMPL may, by a written order given to the contractor at any time during the currency of the contract, amend the contract by making alterations and modifications within the general scope of contract in any one or more of the following:

Tender- Construction of Class Room at Pindrakuli Primary School of Salboni Block, Paschim Midnapore.

- (a) Specifications, drawings, designs etc. where work will be executed under the contract are to be specially manufactured for BRBNMPL,
- (b) mode of packing,
- (c) incidental services to be provided by the supplier
- (d) mode of dispatch,
- (e) place of delivery, and
- (f) any other area(s) of the contract, as felt necessary by BRBNMPL depending on the merits of the case.

19.2. In the event of any such modification/ alteration causing increase or decrease in the cost of goods and services to be supplied and provided, or in the time required by the contractor to perform any obligation under the contract, an equitable adjustment shall be made in the contract price and/ or contract delivery schedule, as the case may be, and the contract amended accordingly. If the contractor doesn't agree to the adjustment made by BRBNMPL, the contractor shall convey its views to BRBNMPL within twenty one days from the date of the contractor's receipt of BRBNMPL's amendment / modification of the contract.

19.3. Option Clause: By a suitable provision in the SCC, the Purchaser may reserve the right to increase the ordered quantity by **25%** at any time, till final delivery date of the contract, by giving reasonable notice even though the quantity ordered initially has been supplied in full before the last date of Delivery Period.

20. Prices

20.1. Prices to be charged by the contractor for supply of goods and provision of services in terms of the contract shall not vary from the corresponding prices quoted by the contractor in its tender or during negotiations, if any, and incorporated in the contract except for any price adjustment authorized in the SCC.

21. Taxes and Duties

21.1. Contractor shall be entirely responsible for all taxes, duties, fees, levies etc. incurred until delivery of the contracted goods to BRBNMPL.

21.2. Further instruction, if any, shall be as provided in the SCC.

22. Terms and Mode of Payment: Unless specified otherwise in SCC, the terms of payments would be as follows:

22.1. TERMS OF PAYMENT:

- a. The contractor shall not be paid any mobilization advance or any secured advance.
- b. Bill in duplicate addressed to the General Manager may be submitted at the end of successful completion of work.
- c. Final Bill shall be raised within 15days after completion of the total work.

Tender- Construction of Class Room at Pindrakuli Primary School of Salboni Block, Paschim Midnapore.

- d. Payment shall be processed against submission of security deposit amounting 10% of contract value (including tax) in form of DD payable at Salboni.
- e. 100% Payment shall be made after the successful completion of work based on satisfactory performance of the work, submission of completion certificate, warranty certificate and original bill.
- f. Statutory deduction of taxes shall be made at source as per existing rules.
- g. Proportionate amount from the bill shall be deducted if the contractor fails to comply with any of the responsibilities and non-compliance of scope of work mentioned in schedules. Such amount shall be decided by the BRBNMPL and shall be binding on the contractor.
- h. Final payment shall be released based on actual work done measurements.

22.2. For Domestic Goods: Unless otherwise specified in the SCC, payments to suppliers are usually made by account payee cheque or through ECS only.

22.3. Unless specified otherwise in the SCC, the following general conditions will apply for payment to the supplier.

22.4. The payment shall be made in the currency / currencies authorized in the contract.

22.5. The contractor shall send its claim for payment in writing when contractually due, along with relevant documents etc., duly signed with date, as specified in SCC and in a manner as also specified therein.

22.6. While claiming payment, the contractor is also to certify in the bill that the payment being claimed is strictly in terms of the contract and all the obligations on the part of the contractor for claiming that payment has been fulfilled as required under the contract.

22.7. The important documents which the supplier is to furnish while claiming payment are:

[Not Applicable]

- a) Original Invoice
- b) Packing List
- c) Certificate of country of origin of the goods from seller's Chamber of Commerce.
- d) Certificate of pre-dispatch inspection by BRBNMPL's representative/ nominee
- e) Manufacturer's test certificate
- f) Performance/ Warrantee Bond
- g) Certificate of insurance
- h) Clean on Bill of lading/ Airway bill/ Rail receipt or any other dispatch document, issued by a government agency (like postal department) or an agency duly authorized by the concerned ministry/ department
- i) Consignee's Certificate confirming receipt and acceptance of goods
- j) Dangerous Cargo Certificate, if any, in case of imported goods.
- k) Any other document specified.

Tender- Construction of Class Room at Pindrakuli Primary School of Salboni Block, Paschim Midnapore.

22.8. While claiming reimbursement of duties, taxes etc. (like sales tax, excise duty, custom duty) from BRBNMPL, as and if permitted under the contract, the contractor shall also certify that, in case it gets any refund out of such taxes and duties from the concerned authorities at a later date, it (the supplier) shall refund to BRBNMPL, BRBNMPL's share out of such refund received by the supplier. The contractor shall also refund the applicable amount to BRBNMPL immediately on receiving the same from the concerned authorities.

22.9. In case where the contractor is not in a position to submit its bill for the balance payment for want of receipted copies of Inspection Note from the consignee and the consignee has not complained about the non-receipt, shortage, or defects in the supplies made, balance amount will be paid by the paying authority without consignee's receipt certificate after three months from the date of the preceding part payment for the goods in question, subject to the following conditions:.

- (a) The supplier will make good any defect or deficiency that the consignee (s) may report within six months from the date of dispatch of goods.
- (b) Delay in supplies, if any, has been regularized.
- (c) The contract price where it is subject to variation has been finalized.
- (d) The supplier furnishes the following undertakings:

“I/We, _____ certify that It We have not received back the Inspection Note duly receipted by the consignee or any communication from BRBNMPL or the consignee about non-receipt, shortage or defects in the goods supplied. I / We agree to make good any defect or deficiency that the consignee may report within three months from the date of receipt of this balance payment or six months from the date of dispatch whichever is later.

23. Delay in the contractor's performance

23.1. The time for and the date specified in the contract or as extended for the delivery of the stores shall be deemed to be the essence of the contract and the contractor shall deliver the goods and perform the services under the contract within the time schedule specified by BRBNMPL in the List of Requirements and as incorporated in the contract.

23.2. Subject to the provision under GCC clause 28, any unexcused delay by the contractor in maintaining its contractual obligations towards execution of work shall render the contractor liable to any or all of the following sanctions besides any administrative action:

- a) Imposition of liquidated damages,
- b) Forfeiture of its EMD and
- c) Termination of the contract for default.

23.3. If at any time during the currency of the contract, the contractor encounters conditions hindering timely delivery of the goods and performance of services, the contractor shall promptly inform BRBNMPL in writing about the same and its likely duration and make a request to BRBNMPL for extension of the delivery schedule accordingly. On receiving the contractor's communication, BRBNMPL shall examine the situation as soon as possible and, at its discretion, may agree to extend the delivery schedule, with or without liquidated damages for completion of contractor's contractual obligations by issuing an amendment to the contract.

Tender- Construction of Class Room at Pindrakuli Primary School of Salboni Block, Paschim Midnapore.

23.4. When the period of construction is extended due to unexcused delay by the contractor, the amendment letter extending the delivery period shall, inter alia contain the following conditions:

- a) BRBNMPL shall recover from the contractor, under the provisions of the clause 24 of the General Conditions of Contract, liquidated damages on the goods and services, which the contractor has failed to deliver within the delivery period stipulated in the contract.
- b) That no increase in price on account of any ground, whatsoever, including any stipulation in the contract for increase in price on any other ground and, also including statutory increase in or fresh imposition of customs duty, excise duty, sales tax or on account of any other tax or duty which may be levied in respect of the goods and services specified in the contract, which takes place after the date of delivery stipulated in the contract shall be admissible on such of the said goods and services as are delivered and performed after the date of the delivery stipulated in the contract.
- c) But nevertheless, BRBNMPL shall be entitled to the benefit of any decrease in price on account of reduction in or remission of customs duty, excise duty, sales tax or any other duty or tax or levy or on account of any other grounds, which takes place after the expiry of the date of delivery stipulated in the contract.

23.5. The contractor shall not execute the work after expiry of the completion period. The contractor is required to apply to BRBNMPL for extension of contract period and obtain the same before continuing the work after contract period. In case the contractor executes the work without obtaining an extension, it would be doing so at its own risk and no claim for payment for such work and / or any other expense related to such work shall lie against BRBNMPL.

24. Liquidated damages

Subject to GCC clause 28, if the contractor fails to deliver any or all of the goods or fails to perform the work within the time frame(s) incorporated in the contract, BRBNMPL shall, without prejudice to other rights and remedies available to BRBNMPL under the contract, deduct from the contract price, as liquidated damages, a sum equivalent to the 0.5% percent (or any other percentage if prescribed in the SCC) of the delivered/ contract price of the delayed goods and/ or services for each week of delay or part thereof until actual delivery or performance, subject to a maximum deduction of the 10% (or any other percentage if prescribed in the SCC) of the delayed goods' or services' contract price(s). During the above-mentioned delayed period of work and / or performance, the conditions incorporated under GCC sub-clause 23.4 above shall also apply.

25. Custody and Return of BRBNMPL's Materials/ Equipment/ Documents loaned to Contractor

25.1. Whenever stores are required to be issued to the firm/contractor for fabrication or prototypes or sub-assemblies are issued for guidance in fabrication, these would be issued against appropriate Bank Guarantee as specified in SCC. In addition to the Bank Guarantee, appropriate insurance may be asked if specified in the SCC.

Tender- Construction of Class Room at Pindrakuli Primary School of Salboni Block, Paschim Midnapore.

25.2. All drawings and samples issued to the contractor in connection with the contract must be returned by him. Final payment will be withheld if this is not done, besides any other sanction deemed fit by BRBNMPL.

26. Termination for default

26.1. BRBNMPL, without prejudice to any other contractual rights and remedies available to it (BRBNMPL), may, by written notice of default sent to the contractor, terminate the contract in whole or in part, if the contractor fails to deliver any or all of the goods or fails to perform any other contractual obligation(s) within the time period specified in the contract, or within any extension thereof granted by BRBNMPL pursuant to GCC sub-clauses 23.3 and 23.4.

26.2. In the event of BRBNMPL terminates the contract in whole or in part, pursuant to GCC sub-clause 26.1 above, BRBNMPL may procure goods and/ or services similar to those cancelled, with such terms and conditions and in such manner as it deems fit at the "Risk and Cost" of the contractor and the contractor shall be liable to BRBNMPL for the extra expenditure, if any, incurred by BRBNMPL for arranging such procurement.

26.3. Unless otherwise instructed by BRBNMPL, the contractor shall continue to perform the contract to the extent not terminated.

27. Termination for insolvency

27.1. If the contractor becomes bankrupt or otherwise insolvent, BRBNMPL reserves the right to terminate the contract at any time, by serving written notice to the contractor without any compensation, whatsoever, to the contractor, subject to further condition that such termination will not prejudice or affect the rights and remedies which have accrued and / or will accrue thereafter to BRBNMPL.

28. Force Majeure

28.1. In the event of any unforeseen event directly interfering with the supply of stores arising during the currency of the contract, such as war, hostilities, acts of the public enemy, civil commotion, sabotage, fires, floods, explosions, epidemics, quarantine restrictions, strikes, lockouts, or acts of God, the Contractor shall, within a week from the commencement thereof, notify the same in writing to the Purchaser with reasonable evidence thereof. Unless otherwise directed by BRBNMPL in writing, the contractor shall continue to perform its obligations under the contract as far as reasonably practical, and shall seek all reasonable alternative means for performance not prevented by the Force Majeure event. If the force majeure condition(s) mentioned above be in force for a period of 90 days or more at any time, either party shall have the option to terminate the contract on expiry of 90 days of commencement of such force majeure by giving 14 days' notice to the other party in writing. In case of such termination, no damages shall be claimed by either party against the other, save and except those which had occurred under any other clause of this contract prior to such termination.

Tender- Construction of Class Room at Pindrakuli Primary School of Salboni Block, Paschim Midnapore.

28.2. Notwithstanding the provisions contained in GCC clauses 23, 24 and 26, the contractor shall not be liable for imposition of any such sanction so long the delay and/ or failure of the contractor in fulfilling its obligations under the contract is the result of an event of Force Majeure.

28.3. In case due to a Force Majeure event BRBNMPL is unable to fulfill its contractual commitment and responsibility, BRBNMPL will notify the contractor accordingly and subsequent actions taken on similar lines described in above sub-paragraphs.

29. Termination for convenience

29.1. BRBNMPL reserves the right to terminate the contract, in whole or In part for its (BRBNMPL's) convenience, by serving written notice on the contractor at any time during the currency of the contract. The notice shall specify that the termination is for the convenience of BRBNMPL. The notice shall also indicate inter-alia, the extent to which the contractor's performance under the contract is terminated, and the date with effect from which such termination will become effective.

29.2. The goods and services which are complete and ready in terms of the contract for delivery and performance within thirty days after the contractor's receipt of the notice of termination shall be accepted by BRBNMPL following the contract terms, conditions and prices. For the remaining goods and services, BRBNMPL may decide:

- a. to get any portion of the balance completed and delivered at the contract terms, conditions and prices; and / or
- b. to cancel the remaining portion of the work and compensate the contractor by paying an agreed amount for the cost incurred by the contractor towards the remaining portion of the work.

30. Governing language

30.1. The contract shall be written in English language following the provision as contained in GIT clause 2. All correspondence and other documents pertaining to the contract, which the parties exchange, shall also be written accordingly in that language.

31. Notices

31.1. Notice, if any, relating to the contract given by one party to the other, shall be sent in writing or by cable or telex or facsimile and confirmed in writing, the procedure will also provide the sender of the notice, the proof of receipt of the notice by the receiver. The addresses of the parties for exchanging such notices will be the addresses as incorporated in the contract.

31.2. The effective date of a notice shall be either the date when delivered to the recipient or the effective date specifically mentioned in the notice, whichever is later.

Tender- Construction of Class Room at Pindrakuli Primary School of Salboni Block, Paschim Midnapore.

32. Code of Ethics

BRBNMPL as well as Bidders, Suppliers, Contractors, and Consultants under BRBNMPL contracts shall observe the highest standard of ethics during the procurement or execution of such contracts. In pursuit of this policy, for the purposes of this provision, the terms set forth below are defined as follows:

- (a) "Corrupt practice" means the offering, giving, receiving, or soliciting, directly or indirectly, of anything of value to influence the action of a public official in the procurement process or in contract execution;
- (b) "Fraudulent practice" means a misrepresentation or omission of facts in order to influence a procurement process or the execution of a contract;
- (c) "Collusive practice" means a scheme or arrangement between two or more Bidders, with or without the knowledge of the Purchaser, designed to establish bid prices at artificial, non competitive levels; and
- (d) "Coercive practice" means harming or threatening to harm, directly or indirectly, persons or their property to influence their participation in the procurement process or affect the execution of a contract.
- (e) A particular violation of ethics may span more than one of above mentioned unethical practices.

32.1. The following policies will be adopted in order to maintain the standards of ethics during procurement:

- (a) A proposal for award will be rejected if it is determined that the Bidder recommended for award has, directly or through an agent, engaged in corrupt, fraudulent, collusive or coercive practices in competing for the Contract in question.
- (b) A contract will be cancelled if it is determined at any time that BRBNMPL representatives/ officials have directly or indirectly, engaged in corrupt, fraudulent, collusive or coercive practices during the procurement or the execution of that contract
- (c) In case any individual staff is found responsible, suitable disciplinary proceedings should be initiated against such staff under the applicable government conduct rules. The existing provisions under the Indian law including the instructions of Central Vigilance Commission should be followed in this regard.
- (d) Firms or individuals shall be banned/ blacklisted after following due process, including declaring them ineligible, either indefinitely or for a stated period of time, to be awarded a BRBNMPL contract, if it at any time determines that they have, directly or through an agent, engaged in corrupt, fraudulent, collusive or coercive practices in competing for, or in executing, a BRBNMPL contract.

33. Resolution of disputes

33.1. If dispute or difference of any kind shall arise between BRBNMPL and the contractor in connection with or relating to the contract, the parties shall make every effort to resolve the same amicably by mutual consultations. If the parties fail to resolve their dispute or difference by such mutual consultation within twenty one days of its occurrence, then, unless otherwise provided in the SCC, either BRBNMPL or the contractor may seek recourse to settlement of disputes through arbitration as per The Arbitration and conciliation Act 1996 as per following clause.

Tender- Construction of Class Room at Pindrakuli Primary School of Salboni Block, Paschim Midnapore.

33.2. Arbitration Clause: - If both parties fail to reach such amicable settlement, then either party (the Purchaser or Seller) may within 21 days of such failure give a written notice to the other party requiring that all matters in dispute or difference be arbitrated upon. Such written notice shall specify the matters which are in difference or of difference of which such written notice has been given and no other matter shall be referred to the arbitration in accordance with the conciliation and arbitration rules of International Chamber of Commerce {ICC}/United National Commission on International Trade Law (UNCITRL) by three arbitrators appointed in accordance with the procedure set out in clause below. The arbitration proceeding shall be held in Kolkata and shall be conducted in English language. All documentation to be reviewed by the arbitrators and/ or submitted by the parties shall be written or translated into English. Venue of arbitration shall be Kolkata. The arbitrator or arbitrators appointed under this article shall have the power to extend time to make the award with the consent of the parties. Pending reference to arbitration the parties shall make all endeavors to complete the contract/work in all respects and all disputes, if any, will finally be settled in the arbitration.

34. Applicable Law

34.1. The contract shall be interpreted in accordance with the laws of India.

34.2. Irrespective of the place of delivery, or the place of performance or the place of Payments under the contract, the contract shall be deemed to have been made at the place from which the notification of acceptance of the tender has been issued.

34.3 Contractor shall be responsible to fulfil all the obligations under various labour laws, such as Contract Labour (Regulation & Abolition) Act, 1970; Minimum Wages Act; Payment of Wages Act; Payment of Bonus act; Payment of Gratuity Act; ESI Act; Employees Provident Funds & Miscellaneous Act; Workmen's Compensation Act etc. The Contractor should arrange to cover all his workmen under as per the applicable labour law. The contractor has to obtain insurance coverage to all his employees under Workmen Compensation Policy during the full tenure of the contract to address the liability under Workmen's Compensation Act. 1923 and the same has to be submitted before commencement of work.

The contractor shall, throughout the contract period has to comply with relevant Central and State statutes, Ordinance or Laws and the regulations or byelaws of any local or duly constituted authority-having jurisdiction over the contract work. The contractor should provide safety equipment like safety shoes, gloves, goggles etc. to their workmen as and when required. The contractor shall also bring to our notice and pay all fees, taxes, dues and contributions required to be given or paid under any Central or State Statutes, Ordinance or other laws or any regulations or bye laws of any local or duly constituted authority in relation to the contractor. The contractor shall get him registered and / or obtain License (s) from the concerned authority as provided under various applicable acts and shall be directly responsible to such authorities for compliance with the provisions thereof. The company, as a principal employer, shall enforce the provisions of these acts, if found necessary. The contractor shall indemnify the company from any claims, which may arise for any breach of the statutory requirements.

Tender- Construction of Class Room at Pindrakuli Primary School of Salboni Block, Paschim Midnapore.

34.4. Rights of The Company – It is obligatory on the part of the company to accept / reject any / all tenders (including part also) without assigning reason thereof. Unjustified / unrealistic bids shall not be considered. Counter condition in any form is not acceptable. The decision of the tender opening / evaluation committee regarding short listing of agencies shall be final and binding on all the bidders. Once the tender is submitted, no change in price will be allowed for any reason. No claim shall be considered to the bidders for not qualifying in Techno-commercial Bid due to any reason whatsoever and BRBNMPL is not bound to intimate such parties.

Incase successful Contractor fails to start the work after placing work order or leave the site without completing the total work, the Contract shall be terminated and EMD including security deposit shall be forfeited. In such case, the name of agency shall be blacklisted and the contractor will be delisted from our approved list.

35. Secrecy

35.1. The Contractor shall take all reasonable steps necessary to ensure that all persons employed in any work in connection with the contract, have full knowledge of the Official Secrets Act and any regulations framed thereunder.

35.2. Any information obtained in the course of the execution of the contract by the Contractor, his servants or agents or any person so employed, as to any matter whatsoever, which would or might be directly or indirectly, of use to any enemy of India, must be treated secret and shall not at any time be communicated to any person.

35.3. Any breach of the aforesaid conditions shall entitle the Purchaser to cancel the contract and to purchase or authorize the purchase of the stores at the risk and cost of the Contractor, In the event of such cancellation, the stores or parts manufactured in the execution of the contract shall be taken by the Purchaser at such price as he considers fair and reasonable and the decision of the Purchaser as to such price shall be final and binding on the Contractor.

Tender- Construction of Class Room at Pindrakuli Primary School of Salboni Block, Paschim Midnapore.

Section V: Special Conditions of Contract (SCC)

The following Special Conditions of Contract (SCC) will apply for this purchase/work. The corresponding clauses of General Conditions of Contract (GCC) relating to the SCC stipulations have also been incorporated below. These Special Conditions will modify / substitute / supplement the corresponding (GCC) clauses.

Whenever there is any conflict between the provision in the GCC and that in the SCC, the provision contained in the SCC shall prevail.

(Clauses of GCC listed below include a possibility for variation in their provisions through SCC. There could be other clauses in SCC as deemed fit).

S. No	GCC Clause No.	Topic	SCC Provision
1	8.0,8.1,8.2,8.3	Packing Marking	Not applicable
2	11.2	Transportation of Domestic Goods	As applicable
3	12.2	Insurance	As applicable
4	14.1	Incidental Services	As applicable
5	15	Distribution of Dispatch Documents for clearance / Receipt of Goods	Not applicable
6	16.2,	Warrantee Clause	As applicable
	16.4		As applicable
7	19.3	Option Clause	As applicable
8	20.1	Price.	As applicable
9	21.1	Taxes and Duties	As applicable
10	22, 22.1, 22.2, 22.3, 22.4, 22.6	Terms and Mode of Payments	As applicable
11	24.0	Quantum of LD	As applicable
12	25.1	Bank Guarantee and Insurance for Material loaned to Contractor.	Not applicable
13	33.1	Resolution of Disputes.	As applicable

1. INSPECTION:

Inspection shall be done at each and every stage by CSR cell of BRBNMPL at the location/work site.

All points mentioned in Section IV of GCC clause 9 shall also prevail.

Tender- Construction of Class Room at Pindrakuli Primary School of Salboni Block, Paschim Midnapore.

Section VI: Questionnaire

Tender No: 03/SAL/CSR/2016-17

A. BASIC INFORMATION:

SL. NO.	PARTICULARS	INFORMATION TO BE FURNISHED BY THE BIDDER
01.	Name of the Firm	
02.	Address for all correspondence with Telephone / Fax. No. / e-mail ID	
03.	Type of Organisation with proof.	Partnership / Proprietary / Ownership / Certificate of Incorporation
04.	Company / Firm Registration No. and date (Copy of certificate to be furnished).	
05.	Professional Tax Registration Number (Copy of Registration to be furnished)	
06.	Service Tax Registration Number (Copy of Registration to be furnished)	
07.	Sales Tax (VAT / CST) Registration Number (Copy of Registration to be furnished)	
08.	Income Tax PAN Card Number (Copy of Card to be furnished)	
09.	Turn over for last three financial years. (Copy of Profit & Loss Account, Balance Sheet & Income Tax return to be furnished)	Year End 31/03/15: Year End 31/03/14: Year End 31/03/13:
10.	Experience in the field of Similar Nature of works only highest magnitude to be mentioned here) Details to be furnished as per attached format along with copy of Work order & Completion certificate.	
11.	No. of permanent technical persons available in the firm (a separate list may be enclosed)	
12.	Any Civil Suit/Litigation arisen/pending in any contract undertaken. (if yes, please furnish the details)	
13.	Whether the company / firm was banned or de-listed by any department of Govt or quasi Govt. agencies or PSUs in last 5 years.	
14.	Any other relevant information, the bidder would like to furnish in connection with its credentials. (Details in separate sheet)	

It is certified that the information furnished above are true. We undertake that in the event of any information found to be false and/or inadequate, our tender shall summarily be rejected and the EMD shall be forfeited without any reference to us.

Date:

Signature of the Bidder with Date

Place:

(Seal of the Firm)

Tender- Construction of Class Room at Pindrakuli Primary School of Salboni Block, Paschim Midnapore.

DETAILS OF WORK EXPERIENCE FORMAT (Tender No.: 03/ SAL / CSR /2016-17)

(Use separate sheet, if space is found inadequate)

SL. No.	Name of the Principal Employer/Owner/ company and the address with telephone No./Fax No./Email and contact persons	Name of the work/Contract	Whether the experience in O&M/Erection & Commissioning	Work Order/LOI No. and date	Period of Contract	Contract Price	No. of persons Deployed (Enclose the list of technical persons separately)	Remarks

Signature of the Bidder with Date

Date:

Place:

(Seal of the Firm)

Section VII: Technical Specifications

1) TECHNICAL SPECIFICATION

a. Plain Cement Concrete (P.C.C.)

Plain Cement concrete of nominal mix 1:2:4 shall be provided using 20 mm down graded stone chips, using minimum grading zone –III sand as per IS : 383 and 43 grade Ordinary Portland Cement (OPC) or Portland Slag Cement. P.C.C. shall be Machine mixed and compacted properly using mechanical vibrator while laying and shall be covered with gunny bags for at least 10 days for curing.

b. Reinforced Cement Concrete (R.C.C.)

The following nominal Mix Concrete shall used as R.C.C.

R.C.C of nominal mix 1:1.5:3 shall be provided by volumetric batch mixing in Mechanical Concrete Mixer. R.C.C. shall be made by using 20 mm down stone aggregate and minimum Zone-III sand. 43 grade OPC or PSC shall be used along with maximum Water Cement Ratio of 0.55.

Type Of Cement Recommended – OPC / PSC or higher grade cement shall only be used. Preferred brand are Konark, L & T, ACC, Lafarge, Grasim or equivalent.

c. Bricks - Only 1st Class approved quality of IS standard bricks shall be used.

Min. de-shuttering period: Column :- 48 hours, Beam & slab – minimum 7days / as advised by EIC

Min. Curing period : All R.C.C. shall be cured for minimum 10 days and maximum as desired by the Engineer-in-Charge.

d. Reinforcement Works : Reinforcing bars for concrete shall be round high yield deformed steel bars conforming to IS : 1786. Preferably Tata / Ticon or equivalent make.

e. Weather Coat All Guard: Protective and Decorative Acrylic exterior emulsion paint (Weather Coat All Guard) of approved quality, as per manufacturer's specification. Preferred Brand Asian Paints / Burger paints or equivalent.

f. Type of Pipes : Conforming to ASTM D - 1785 to match with G.I. pipes TATA make as per I.S: 1239 (part-I), PVC pipe preferably Supreme / Oriplast or equivalent make.

Tender- Construction of Class Room at Pindrakuli Primary School of Salboni Block, Paschim Midnapore.

Section VIII: Quality Control Requirements

The workman ship and quality of the materials to be used should be strictly in accordance with the brand and specification as mentioned in Technical specification Section VII.

Section IX: Qualification/ Eligibility Criteria

PRE-QUALIFICATION / ELIGIBILITY CRITERIA:

i) Turn over:

Average annual financial turn over during last 3 years ending 31st March 2015 should be at least Rs.: **3,22,000/-** (Rupees: Three lakh Twenty two thousand only)

ii) Experience:-

Details of experience as contractor/ firm with respect to Construction of Class Room / similar work maximum order value, and resource mobilized with documentary proof shall be submitted:

One similar completed work for the value not less than **Rs. 8,58,000/-** (Rupees: Eight lakh Fifty eight thousand only) during last 7 years upto **31.03.2016**.

OR

Two similar completed works for the value not less than Rs. **5,36,000/-** (Rupees: Five lakh Thirty six Thousand only) during last 7 years upto **31.03.2016**.

OR

Three similar completed works for the value not less than Rs. **4,29,000/-** (Rupees: Four lakh Twenty Nine thousand only) during last 7 years upto **31.03.2016**.

iii) The bidder firm should not have suffered any financial loss for more than one year during last three years upto **31.03.2015**

iv) The net worth of the firm should not have eroded by more than 30% during last 3 years upto **31.03.2015**.

v) The bidder firm shall be registered for VAT / CST, Service Tax and Professional Tax, Profit and loss Account and Balance sheet for the last three years ending 31st March'2015

Bidder has to furnish stipulated documents in support of fulfillment of qualifying criteria. All financial data shall be certified by the Chartered Accountant. Non-submission or incomplete submission of documents may lead to rejection of offer.

Tender- Construction of Class Room at Pindrakuli Primary School of Salboni Block, Paschim Midnapore.

Section X: Tender Form

Date

To
The General Manager
B.R.B.N.M.P.L
PO: RBNM, Salboni
West Midnapore District
West Bengal – 721132

Ref: Your Tender document No. dated

We, the undersigned have examined the above mentioned tender enquiry document, including amendment No. _____, dated _____ (if any), the receipt of which is hereby confirmed. We now offer to execute the work of **Construction of Class Room at Pindrakuli Primary School of Salboni Block, Paschim Midnapore.** in conformity with your above referred document. If our tender is accepted, we undertake to execute the above work in accordance with the delivery schedule specified in the List of Requirements.

We agree to keep our tender valid for acceptance for a period upto as required in the GIT clause 19, read with modification, if any in Section-III — "Special Instructions to Tenderers" or for subsequently extended period, if any, agreed to by us. We also accordingly confirm to abide by this tender upto the aforesaid period and this tender may be accepted any time before the expiry of the aforesaid period. We further confirm that, until a formal contract is executed, this tender read with your written acceptance thereof within the aforesaid period shall constitute a binding contract between us.

We further understand that you are not bound to accept the lowest or any tender you may receive against your above-referred tender enquiry.

Dated this _____ day of _____

For & on behalf of

(Signature with date)

(Name and designation)

Duly authorized to sign tender for and on behalf of

.....

Tender- Construction of Class Room at Pindrakuli Primary School of Salboni Block, Paschim Midnapore.

Section XI: Price Schedule & Drawing

Tender Number: 03/SAL/CSR/2016-17
(To be submitted in Separate Sealed Enclosed Envelope)

Construction of Class Room at Pindrakuli Primary School of Salboni Block, Paschim Midnapore.

Item No.	Description of Item	Unit	Quantity	Rate (Rs.)	Amount (Rs.)
1.	Earth work in excavation for trench in all kind of soil including soft rock, moorum etc. up to a lift of 1.50 meters depth in both wet dry condition, bailing out of water, shoring, shuttering (if required) leveling, dressing, ramming the bottom. This includes stacking of serviceable materials, disposal of surplus earth within a lead of 50 meter as per specification, drawings & direction of the Engineer – in – charge. The payment shall be made for the theoretical volume of earthwork in excavation only as per drawing i.e. for the volume of excavation having maximum bottom dimension of the trench as per drawing and the actual depth. The bidder should take into account the quoted rate. Provision shall be made for any excess excavation for necessary working space, slope etc. required for excavation, shuttering and other allied works and refilling the sides.	M ³	35.73		
2.	Fine Sand filling in Flooring in layers not exceeding 150mm. as per drawing, specification, instruction and entire satisfaction of the Engineer-in-Charge and consolidating same by through saturation with water and ramming complete including cost of supply of sand loading, unloading, carriage etc. (Payment to be made on measurement of finished quantity after compaction only.)	M ³	13.79		
				C/F(Rs.)	

Tender- Construction of Class Room at Pindrakuli Primary School of Salboni Block, Paschim Midnapore.

Item No.	Description of Item	Unit	Quantity	Rate (Rs.)	Amount (Rs.)
3.	Single brick flat soling in foundation with picked Jhama bricks including ramming and dressing bed to proper level and filling joints with local fine sand, watering etc. as per specification, drawing and instruction of the Engineer-in-Charge.	M ²	92.70	B/F(Rs.)	
4.	Providing casting and laying of Plain cement concrete (1:2:4) in footing and floor etc. of concrete grade M-15 (1 cement: 2 fine aggregate: 4 coarse aggregate) nominal mix, using 20 mm down, graded stone aggregate (by placing in position as per drawing excluding cost of shuttering and reinforcement, all bye works complete as per drawing and curing the concrete using gunny bags till it attains its maximum strength as per specification, drawing and instruction of the Engineer- in- charge.	M ³	7.28		
5.	Providing 250mm thick 1 st class Brick work with cement mortar 1:6 (1 cement: 6 Sand) proportion in Foundation & Plinth , at Ground floor all lead and depths including curing, scaffolding with all bye-works as per drawing specification and direction of the Engineer-in-charge with approved bricks of class designation – 50.	M ³	3.95		
6.	25mm. thick damp proof course with cement concrete with stone chips (1:1.5:3) [with graded stone aggregate 10 mm nominal size] and admixture of water proofing compound as per manufacturer's specification followed by two coat of polymer based paint, (1st coat after 4 to 5 days of concrete laying and 2 nd coat just before brick masonry work)	M ²	11.21	C/F(Rs.)	

Tender- Construction of Class Room at Pindrakuli Primary School of Salboni Block, Paschim Midnapore.

Item No.	Description of Item	Unit	Quantity	Rate (Rs.)	Amount (Rs.)
	as directed (cost of water proofing compound & polymer based paint to be paid separately). (Chequering not required over concrete or painted surface).			B/F(Rs.)	
7.	Providing 250mm thick 1 st class Brick work with cement mortar 1:6 (1 cement: 6 Sand) proportion in Super Structure , at Ground floor all lead and depths including curing, scaffolding with all bye-works as per drawing specification and direction of the Engineer-in-charge with approved bricks of class designation – 50.	M ³	23.00		
8.	Providing 125 mm thick 1 st class Brick work with cement mortar 1:4 (1 cement: 4 Sand) proportion in Super structure walls, at any location all lead and depths including curing, scaffolding with all bye-works as per drawing, specification and direction of the Engineer-in-charge with approved bricks of class designation – 50.	M ²	29.31		
9.	Providing casting and laying of Plain cement concrete (1:1.5:3) in footing, column, tie beam, lintel etc. of concrete grade M-20 (1 cement: 1.5 fine aggregate: 3 coarse aggregate) nominal mix, using 20 mm down graded stone aggregate (by tying pre-cast concrete cover block with reinforcement & placing in position as per drawing) using mechanical vibrator excluding cost of shuttering and reinforcement, all bye works complete as per drawing and curing the concrete using gunny bags till it attains its maximum strength as per IS specification, drawing and instruction of the Engineer- in-charge.	M ³	31.09	C/F(Rs.)	

Tender- Construction of Class Room at Pindrakuli Primary School of Salboni Block, Paschim Midnapore.

Item No.	Description of Item	Unit	Quantity	Rate (Rs.)	Amount (Rs.)
10.	Supply, fabricating and fixing in position Steel reinforcement at column footing all levels and positions including cost of steel, transport, straitening, cutting, bending, cranking, binding (with 1.626 mm. black annealed wire), welding etc. as per drawings, IS specifications and direction including cost of binding wire, labour etc. all complete for reinforced concrete work as well as pre-cast concrete element work (chairs and space bar shall be measured and paid for). Using HYDS (Fe-415) bars.	MT	4.17	B/F(Rs.)	
11.	Providing, fixing and striping off all types and shapes of steel or 12mm ply board Shuttering for all R.C.C. works not covered in respective items including propping, scaffolding, centering true to line and level firmly with bolts separators tension devices etc. at any depth and heights complete as per the drawing, IS specifications and the instruction of the Engineer- in- Charge.	M ²	291.08		
12.	Providing 35mm thick A.S.F. Flooring/ Skirting / Dado in two layers, consisting of 35 mm thick backing with concrete of grade (1:2:4) using 12mm down stone chips/plaster in cement mortar 1:1 and 10mm thick topping with a mix of cement, sand & stone chips in proportion 1:1:1 using 3mm. down stone chips & finished with a floating coat of neat cement (2.2 kg./ m ²), including 25mm wide X 3mm thick glass strips, all bye-works dabbing, curing, scaffolding complete at all heights and specification as per direction of the Engineer-in-charge.	M ²	75.36	C/F(Rs.)	

Tender- Construction of Class Room at Pindrakuli Primary School of Salboni Block, Paschim Midnapore.

Item No.	Description of Item	Unit	Quantity	Rate (Rs.)	Amount (Rs.)
13.	Supplying, fitting and fixing MS window & window Grills in single or composite units, openable type as per IS:1038 and IS:1361 with all joints flash butt welded including ISA, MS flat, MS sheet, hinges, MS clamps, locking arrangement etc. complete <u>including two coats of painting with synthetic Enamel paint over a coat of primer with approved quality</u> as per drawing and direction of the Engineer-in-Charge. (Mode of measurement- The weight of grill will be measured as per actual weight at the site)	KG	360.00	B/F (Rs.)	
14.	Providing and fixing 35 mm thick (door size 2000 x 1000) mm approved Panelled door shutters with seasoned Local wood styles and rails and panels of specified thickness with 19 mm thick wood particle board including providing fitting and fixing of Steel clamp, 06 Nos. hinges, 300 mm aldrop, 300mm tower bolts, 02 Nos. door rings, 02 Nos. hinge cleat, rubber buffers etc. in each door of approved quality complete as per specification <u>including two coats of painting with synthetic Enamel paint over a coat of primer with approved quality</u> and as per direction of the Engineer –in – Charge.	M ²	8.51		
15.	Supplying fitting and fixing door frame of 125mm. x 75mm. made out of local Sal wood including joinery work and cutting rebates as required with one coat of protective primer on back side and fixing six numbers M.S. clamps as per drawing, specification <u>including two coats of painting with synthetic Enamel paint over a coat of primer with approved quality</u> and as per direction of the Engineer – in – Charge.	M ³	0.20	C/F(Rs.)	

Tender- Construction of Class Room at Pindrakuli Primary School of Salboni Block, Paschim Midnapore.

Item No.	Description of Item	Unit	Quantity	Rate (Rs.)	Amount (Rs.)
16.	Providing 20 mm thick cement plaster for inside wall over brick wall with 1:6 (1 Cement: 6 Sand) cement sand mortar including rounding off or chamfering corners as directed and racking out joints including throating, nosing and drip course, to brick wall, Concrete surface with all bye-works (Cheeping the concrete surface) curing, scaffolding complete at all heights and specification as per direction of the Engineer-in-charge.	M ²	131.61	B/F(Rs.)	
17.	Providing 10 mm thick cement plaster over ceiling area after chipping the surface with 1:4 (1 Cement: 6 Sand) cement sand mortar including rounding off or chamfering corners as directed and racking out joints including throating, nosing and drip course, to brick wall, Concrete surface with all bye-works (Cheeping the concrete surface) curing, scaffolding complete at all heights and specification as per direction of the Engineer-in-charge.	M ²	74.35		
18.	Providing 15 mm thick cement plaster for outside wall over brick wall with 1:6 (1 Cement: 6 Sand) cement sand mortar including rounding off or chamfering corners as directed and racking out joints including throating, nosing and drip course, to brick wall, Concrete surface with all bye-works (Cheeping the concrete surface) curing, scaffolding complete at all heights and specification as per direction of the Engineer-in-charge.	M ²	263.29	C/F(Rs.)	

Tender- Construction of Class Room at Pindrakuli Primary School of Salboni Block, Paschim Midnapore.

Item No.	Description of Item	Unit	Quantity	Rate (Rs.)	Amount (Rs.)
19.	P.V.C. Rain water Spout Conforming to ASTMD - 1785 to match with G.I. pipes TATA make as per I.S: 1239 (part-I), PVC pipe preferably Suprime / Oriplus or equivalent make 80 mm. Dia. and 600 to 750 mm. long supplied fitted and fixed complete.	Each	6.00	B/F (Rs.)	
20.	Providing and laying of Neat cement punning in wall/dado, floor etc. (cement @ 0.152 cum. Per % m ²) with all bye-works dabbing, curing complete at all heights and specification as per direction of the Engineer-in-charge.	M ²	36.60		
21.	Supplying, fitting & fixing 4 mm thick approved best Indian sheet glass panes of plain sheet glass, fixing with standard metal (Aluminium) beads with screw and set in putty (as per IS specification) at any location including cost of scaffolding if and when required as per drawing and direction of the Engineer-in-charge.	M ²	12.96		
22.	Providing and applying two coats of Colour wash of approved shade with strainer and adhesive over a coat of white wash primer on the new plastered surface, inside of room walls, at all locations with all bye-works (scraping the surface thoroughly) including site clearing complete as per specification and direction of the Engineer –in – Charge.	M ²	194.68		
23.	Providing and applying Weather coat all guard Premium 100% Protective and Decorative Acrylic exterior emulsion paint of approved quality, as per manufacturer's specification and as per direction of EIC to be applied over acrylic primer as required. The rate includes cost of material, labour, scaffolding and all incidental charges but excluding the cost of primer.	M ²	237.97	C/F(Rs.)	

Tender- Construction of Class Room at Pindrakuli Primary School of Salboni Block, Paschim Midnapore.

Item No.	Description of Item	Unit	Quantity	Rate (Rs.)	Amount (Rs.)
24.	Supplying, fitting & fixing 25 mm precast cement concrete (9"x 6") Jali 1:2:4 (1 cement : 2 coarse sand: 4 graded stone aggregate 6 mm nominal size), reinforced with 1.6 mm dia mild steel wire, including centering and shuttering, roughening cleaning, fixing and finishing in cement mortar 1:3 (1 cement: 3 fine sand) etc. complete as directed by Engineer-in-charge.	M ²	1.22	B/F(Rs.)	
Cost of Construction of Class Room Rs.:					
Less: Rebate, if any, @ _____% = Rs.:					
Net Amount = Rs.:					
Service Tax @ 15% on 40% of Net Amount (Subject to Change)= Rs.:					
GRAND TOTAL Rs.:					

(Total Amount Rupees :.....)

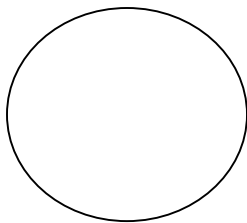

(Signature of the bidder)

PINDERAKULI PRIMARY SCHOOL CLASS ROOM SHEET - 1

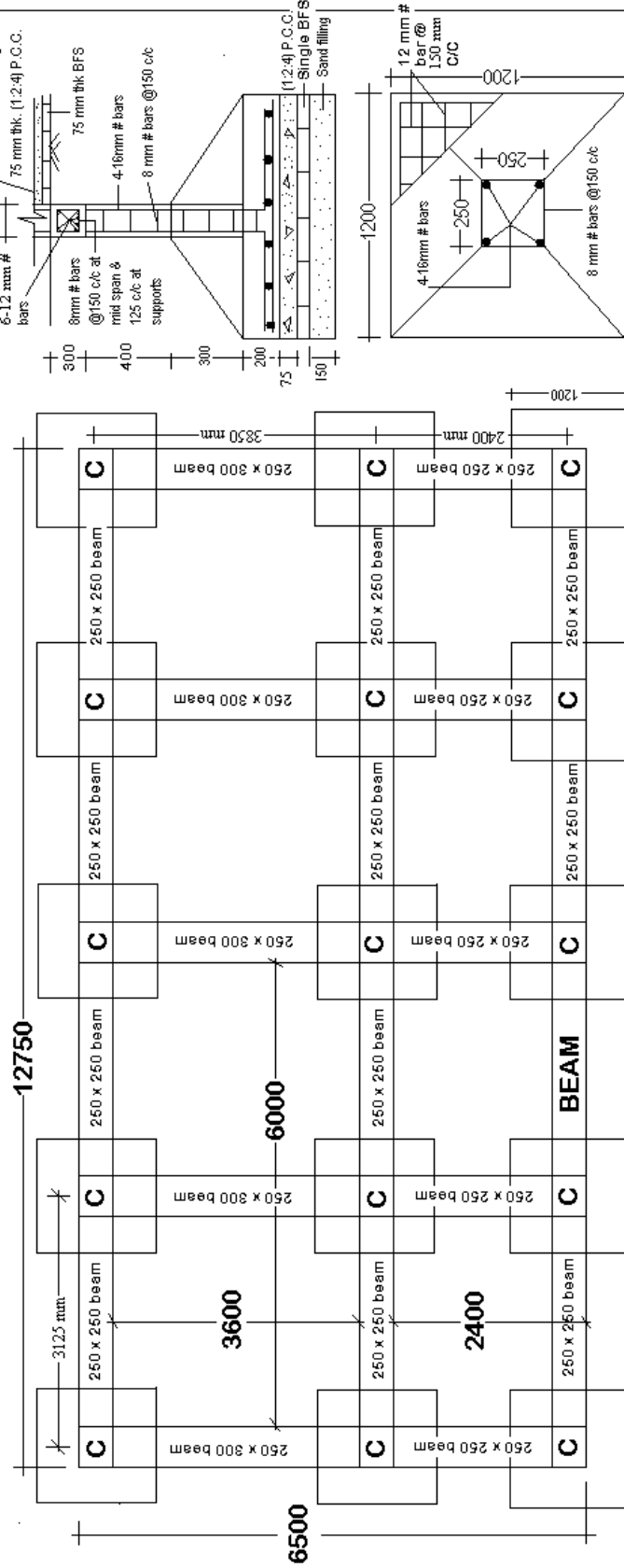

LAYOUT PLAN

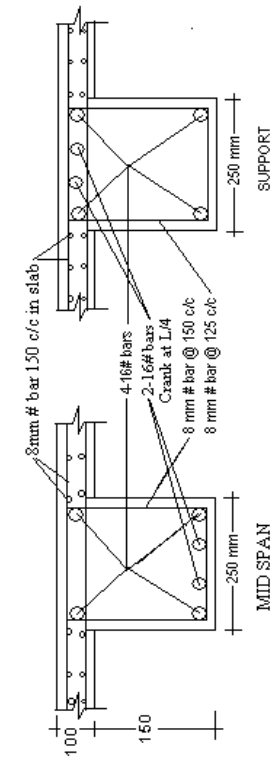

ROOF LEVEL BEAM 250 x 250

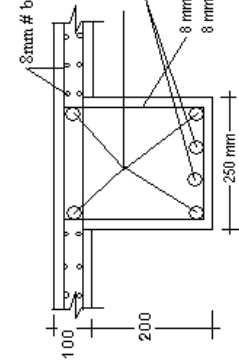

MID SPAN

ROOF LEVEL BEAM 250 x 300

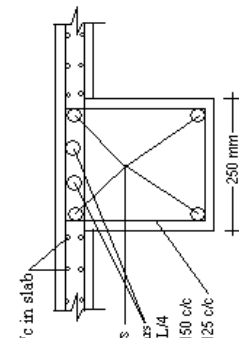

SUPPORT

COLUMN C

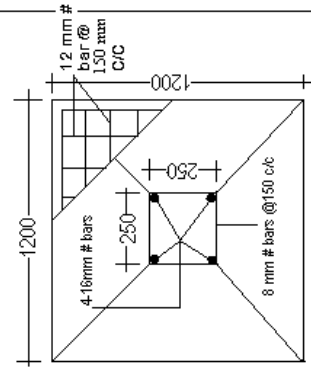
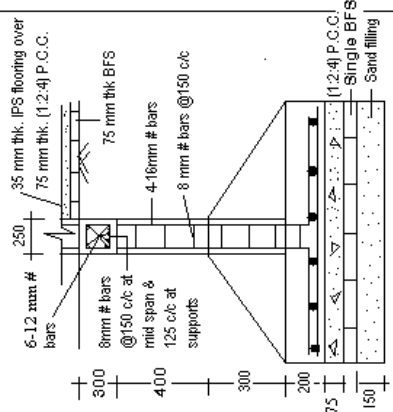

PINDERAKULI PRIMARY SCHOOL CLASS ROOM SHEET - 2

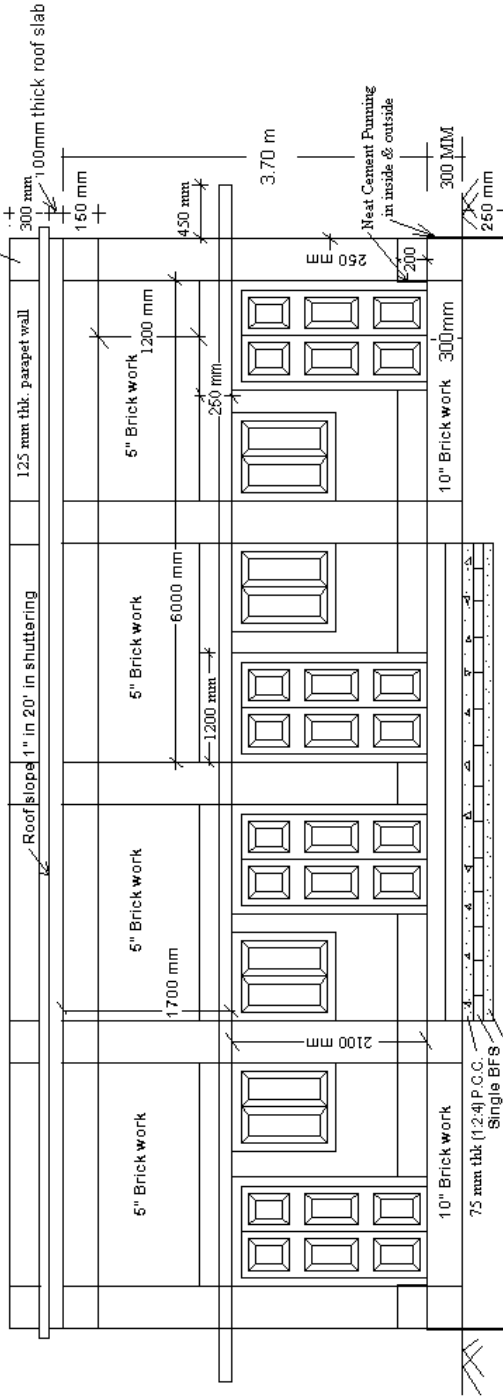

ELEVATION

Crank at L/4

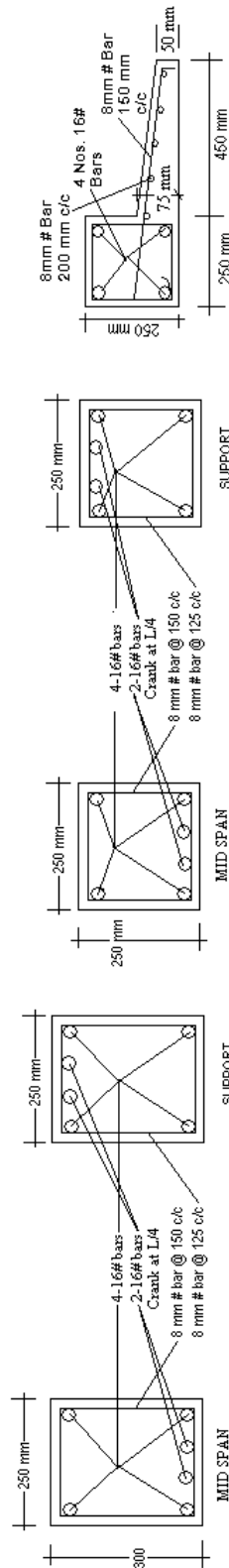

GROUND LEVEL BEAM 250 x 250

GROUND LEVEL BEAM 250 x 300

Lintel

CONSTRUCTION OF CLASS ROOM AT PINSRAKULI PRIMARY SCHOOL, SALBONI BLOCK

Door Frame = 75 X 100

SHEET - 3

Door Shutter = 2025 X 1050

Window = 30Kg each Incl. Grill

450X1200 sunshed

Steel Window = 900 X 1200

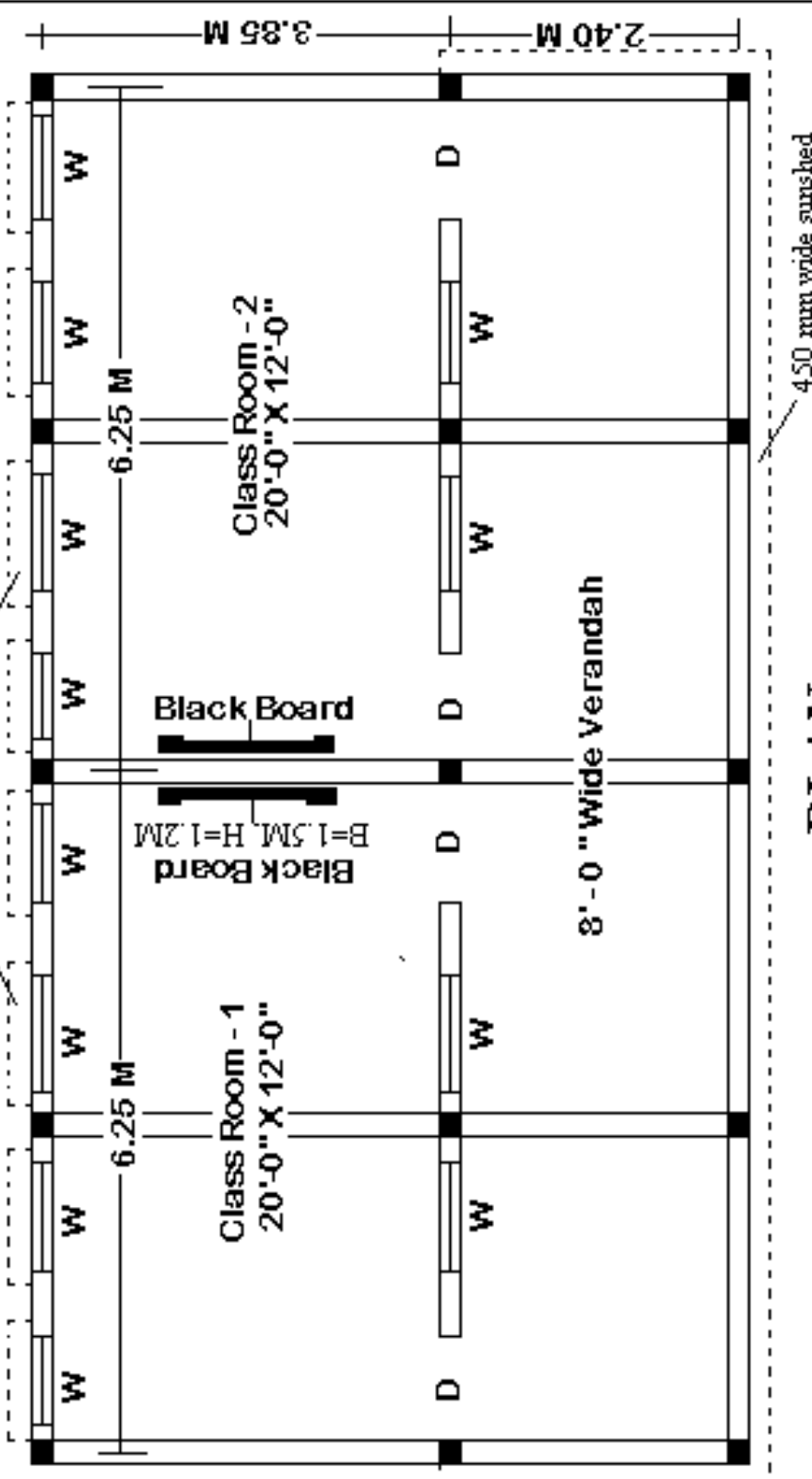

PLAN

Section XII: List of Requirements

1. **EARNEST MONEY DEPOSIT:**

E.M.D.: An EMD of **Rs 21,500/- (Rupees Twenty one thousand Five hundred only)** is payable in the form of Demand Draft / Banker's Cheque / Fixed Deposit drawn in favour of Bharatiya Reserve Bank Note Mudran Pvt. Ltd., payable at par at the State Bank of India, Salboni (Code No.3558) drawn from any Branch of SBI in India. If drawn from any Associate Banks of SBI or any other Scheduled Commercial Bank in India, it should be payable at par at Midnapore. Tender without EMD shall be liable for rejection. EMD will be returned as applicable to the unsuccessful bidders without any interest after the finalization of the contract. For successful bidder, it will be converted as part of Security Deposit, which is 10% of order value and will be returned after completion of Defect Liability Period of one year from virtual date of completion. The successful bidder has to submit balance amount of Security deposit within 21 days after issue of work order. It may be noted that no interest will be paid while returning the EMD / Security Deposit. EMD amount will be forfeited, if any of the bidders fails or refuses to take up the job after opening the quotation and becoming the successful bidder, due to any reason whatsoever without any notice.

2. **Questionnaire in Section-XII must be submitted duly filled in.**

3. **Brief Description of work.**

The tender is for inviting resourceful contractors for **Construction of Class Room at Pindrakuli Primary School of Salboni Block, Paschim Midnapore**. The scope includes RCC, Brick foundation, Brick work, D.P.C., Plastering, Neat cementing, White washing, IPS flooring, Weather Coat All Guard Painting, Construction of Soak pit etc. including all types of work complete in all respect as per BOQ mentioned in Price bid. The detailed specifications of Class Room are as follows.

Size of Footing: 1200 mm x 1200 mm width.

Depth of Footing: 1200 mm.

Size of single Class Room: 3600mm x 6000 mm.

Width of Verandah: 2400mm.

4. **Completion Period**

04 months from the date of issue of Work Order.

SECTION XIII: Bank Guarantee Form for Performance Security

_____ [Insert Bank's Name, and Address of Issuing Branch or Office)
Beneficiary _____ [Insert Name and Address of BRBNMPL]
Date:-----
Performance Guarantee No.-----

WHEREAS (name and Address of the supplier) (hereinafter called "the supplier") has undertaken, in pursuance of contract no Dated to supply (description of goods and services) (herein after called "the contract").

AND WHEREAS it has been stipulated by you in the said contract that the supplier shall furnish you with a bank guarantee by a scheduled commercial bank recognized by you for the sum specified therein as security for compliance with its obligations in accordance with the contract:

AND WHEREAS we have agreed to give the supplier such a bank guarantee; NOW THEREFORE we hereby affirm that we are guarantors and responsible to you, on behalf of the supplier, up to a total of _____ (amount of the guarantee in words and figures), and we undertake to pay you, upon your first written demand declaring the supplier to be in default under the contract and without cavil or argument, any sum or sums within the limits of (amount of guarantee) as aforesaid, without your needing to prove or to show grounds or reasons for your demand or the sum specified therein.

We hereby waive the necessity of your demanding me said debt from the supplier before presenting us with the demand. We further agree that no change or addition to or other modification of the terms of the contract to be performed thereunder or of any of the contract documents which may be made between you and the supplier shall in any way release us from any liability under this guarantee and we hereby waive notice of any such change, addition or modification.

We undertake to pay BRBNMPL up to the above amount upon receipt of its first written demand, without BRBNMPL having to substantiate its demand.

This guarantee will remain in force for a period of forty five days after the period of tender validity and any demand in respect thereof should reach the Bank not later than the above date.

(Signature of the authorized officer of the Bank)
Name and designation of the officer

Seal, name & address of the Bank and address of the Branch

Name and designation of the officer

Seal, name & address of the Bank and address of the Branch

Section XIV: Letter of Authority for attending a Bid Opening

(Refer to clause 24.2 of GIT)

To
The General Manager
BRBNMPL,Salboni.

Subject: Authorization for attending bid opening on _____ (date) in the Tender of

Following persons are hereby authorized to attend the bid opening for the tender mentioned above on behalf of _____ (Bidder) in order of preference given below:

Order of Preference	Name	Specimen Signatures
I.		
II.		
Alternate Representative		
Signature of Bidder or Officer authorized to sign the bid Documents on behalf of the bidder		

(Signature, name and address of the contractor's executive duly authorized to sign on behalf of the contractor)

For and on behalf of

(Name and address of the contractor)

.....

(Seal of the contractor)

Date:

Place:

Note:

1. Maximum of two representatives will be permitted to attend bid opening. In cases where it is restricted to one, first preference will be allowed. Alternate representative will be permitted when regular representatives are not able to attend.
2. Permission for entry to the hall where bids are opened may be refused in case authorization as prescribed above is not produced.

Section XV: Proforma of Bills for Payments

1. Each bill should have SERVICE TAX, PAN, VAT (if any), number printed over the bill.
2. Bill shall be paid as per the actual work done upto the satisfaction of BRBNMPL Authority.
3. Contractor shall submit the first & final bill after successful execution of the total work to the satisfaction of the Engineer-in-Charge.
4. Payment shall be released within fifteen working days after fulfilling all necessary formalities.
5. The Contractor may claim the Service Tax as applicable, but they have to submit the documentary proof of submission of Service Tax within one month from the date of release of payment; otherwise the said amount shall be deducted from the Security Deposit.
6. Contractor should submit undertaking for statutory compliance along with the bill.
7. Statutory deduction of taxes shall be made at source as per rule and provisions.
8. In absence of W.B.V.A.T. registration, Sales Tax will be deducted at source as per applicable rates in addition to the statutory deductions.
9. No claim certificate against the subject work order other than the first and final bill to be submitted by the contractor while raising the bill.

Signature and Stamp of contractor